

This Page Is Inserted by IFW Operations  
and is not a part of the Official Record

## **BEST AVAILABLE IMAGES**

Defective images within this document are accurate representations of the original documents submitted by the applicant.

Defects in the images may include (but are not limited to):

- BLACK BORDERS
- TEXT CUT OFF AT TOP, BOTTOM OR SIDES
- FADED TEXT
- ILLEGIBLE TEXT
- SKEWED/SLANTED IMAGES
- COLORED PHOTOS
- BLACK OR VERY BLACK AND WHITE DARK PHOTOS
- GRAY SCALE DOCUMENTS

**IMAGES ARE BEST AVAILABLE COPY.**

**As rescanning documents *will not* correct images,  
please do not report the images to the  
Image Problems Mailbox.**



INTERNATIONAL APPLICATION PUBLISHED UNDER THE PATENT COOPERATION TREATY (PCT)

<p>(51) International Patent Classification <sup>6</sup> : H04B 1/707, 7/08, 7/26, H04J 3/06</p>	<p>A1</p>	<p>(11) International Publication Number: <b>WO 99/39452</b> (43) International Publication Date: 5 August 1999 (05.08.99)</p>
<p>(21) International Application Number: PCT/JP99/00327 (22) International Filing Date: 27 January 1999 (27.01.99) (30) Priority Data: 09/015,424 29 January 1998 (29.01.98) US (71) Applicant: SHARP KABUSHIKI KAISHA [JP/JP]; 22-22, Nagaiké-cho, Abeno-ku, Osaka-shi, Osaka 545-0013 (JP). (72) Inventors: KOWALSKI, John, M.; 501 S.E. 123rd Avenue #Y-177, Vancouver, WA 98683 (US). KANDARA, Srinivas; Apartment C1, 8701 N.E. 54th Street, Vancouver, WA 98666 (US). SOMAYAZULU, Srinivasa; 12910 S.W. Winterlake Drive, Tigard, OR 97223 (US). (74) Agent: TAKANO, Akichika; 9th floor, Salute Building, 72, Yoshida-cho, Naka-ku, Yokohama-shi, Kanagawa 231-0041 (JP).</p>	<p>(81) Designated States: JP, KR, European patent (AT, BE, CH, CY, DE, DK, ES, FI, FR, GB, GR, IE, IT, LU, MC, NL, PT, SE).  Published With international search report. Before the expiration of the time limit for amending the claims and to be republished in the event of the receipt of amendments.</p>	

(54) Title: SYSTEM AND METHOD FOR ASYNCHRONOUS CDMA CELLULAR COMMUNICATION

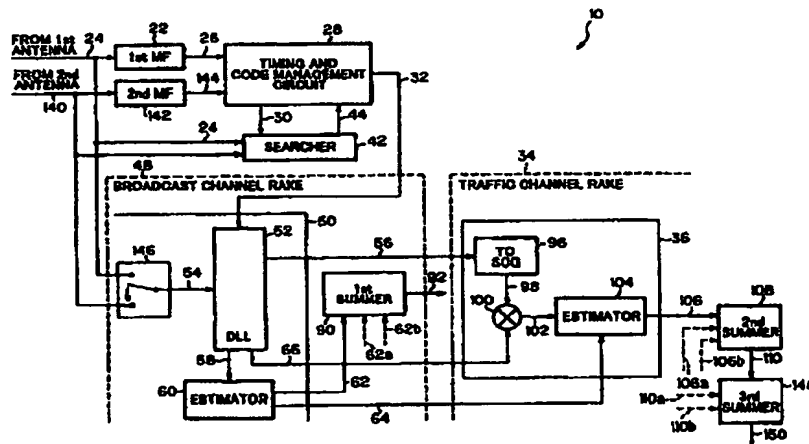

(57) Abstract

A wideband CDMA receiver system to accept messages from asynchronously transmitting base stations is provided. The base station transmission to each receiver includes a perch channel and at least one traffic channel. Although all the channels typically include pilot symbols for the purpose of demodulating the information symbols of the channel, the perch channel includes a higher proportion of pilot symbols to information symbols. Therefore, a perch channel based timing and estimation system is inherently more accurate. In addition, the perch channel is generally transmitted at higher power levels than a traffic channel, and the resulting, higher, signal to noise ratio signal also improves the accuracy of the timing and channel estimation. Based on the timing derived from the perch channel of a first base station, the receiver can set the timing of the traffic channel transmissions from a second base station, to more closely match the timing of traffic channel transmissions from the first base station. In this manner, the signal to noise ration of the demodulated traffic channel information symbols is enhanced through the diversity of using the transmissions of two base stations. A method for receiving wideband CDMA transmissions from asynchronously transmitting base stations is also provided.

**FOR THE PURPOSES OF INFORMATION ONLY**

Codes used to identify States party to the PCT on the front pages of pamphlets publishing international applications under the PCT.

AL	Albania	ES	Spain	LS	Lesotho	SI	Slovenia
AM	Armenia	FI	Finland	LT	Lithuania	SK	Slovakia
AT	Austria	FR	France	LU	Luxembourg	SN	Senegal
AU	Australia	GA	Gabon	LV	Latvia	SZ	Swaziland
AZ	Azerbaijan	GB	United Kingdom	MC	Monaco	TD	Chad
BA	Bosnia and Herzegovina	GE	Georgia	MD	Republic of Moldova	TG	Togo
BB	Barbados	GH	Ghana	MG	Madagascar	TJ	Tajikistan
BE	Belgium	GN	Guinea	MK	The former Yugoslav Republic of Macedonia	TM	Turkmenistan
BF	Burkina Faso	GR	Greece	ML	Mali	TR	Turkey
BG	Bulgaria	HU	Hungary	MN	Mongolia	TT	Trinidad and Tobago
BJ	Benin	IE	Ireland	MR	Mauritania	UA	Ukraine
BR	Brazil	IL	Israel	MW	Malawi	UG	Uganda
BY	Belarus	IS	Iceland	MX	Mexico	US	United States of America
CA	Canada	IT	Italy	NE	Niger	UZ	Uzbekistan
CF	Central African Republic	JP	Japan	NL	Netherlands	VN	Viet Nam
CG	Congo	KE	Kenya	NO	Norway	YU	Yugoslavia
CH	Switzerland	KG	Kyrgyzstan	NZ	New Zealand	ZW	Zimbabwe
CI	Côte d'Ivoire	KP	Democratic People's Republic of Korea	PL	Poland		
CM	Cameroon	KR	Republic of Korea	PT	Portugal		
CN	China	KZ	Kazakistan	RO	Romania		
CU	Cuba	LC	Saint Lucia	RU	Russian Federation		
CZ	Czech Republic	LJ	Liechtenstein	SD	Sudan		
DE	Germany	LK	Sri Lanka	SE	Sweden		
DK	Denmark	LR	Liberia	SG	Singapore		
EE	Estonia						

## SYSTEM AND METHOD FOR ASYNCHRONOUS CDMA CELLULAR COMMUNICATION

### Background and Summary of the Invention

This invention relates generally to cellular telephone  
5 communications, and more particularly to a system and method for mobile  
stations to use the timing information derived from the perch channel of  
an asynchronously transmitting base station to demodulate a traffic  
channel message.

Spread spectrum communication techniques allow  
10 communicating users to operate in noisy radio frequency (RF) spectrums,  
and are especially effective against narrow-band interferers. Spread  
spectrum communications can be effected at relatively low power spectral  
densities, and multiple users can share the same frequency spectrum.  
Further, receivers can be designed to protect against multipath. These  
15 system characteristics encouraged early development of the technology by  
the military.

Common forms of spread spectrum systems include chirp,  
frequency hopping, and direct sequence or pseudonoise (PN). The chirp  
system transmits an impulse signal in the time domain that is spread  
20 monotonically in the frequency domain. A receiver converts the spread  
frequency signal back into an impulse signal. These frequency-spread  
impulse signals have applications in radar, for the pulse position  
modulation of information, or both, such as the R<sup>3</sup> transponder developed  
by General Dynamics, Electronics Division in the 1970s. Frequency  
25 hopping systems communicate by synchronizing users to simultaneously  
change the communication frequency.

Direct Sequence systems spread a digital stream of information, typically in a quadriphase modulation format, with a PN code generator, to phase shift key modulate a carrier signal. The pseudonoise sequence of the PN code generator is periodic, and the spread signal can be despread in a receiver with a matching PN code. Direct Sequence systems have excellent immunity to noise. The PN codes used typically permit a large number of users to share the spectrum, with a minimum of correlation between the user's PN codes. However, Direct Sequence system require large RF bandwidths and long acquisition times.

The IS-95 standard defines key features of the so-called second generation code division multiple access (CDMA) communication system, a type of Direct Sequence spread spectrum modulation. To help solve the problem of long acquisition time, the IS-95 signal uses a pilot channel. Each base station transmits a pilot channel message spread with PN codes known to all the mobile stations. The PN code is made up a series of phase shifted binary symbols called chips. The PN period is 32,768 chips and the PN chip rate is 1.2288 Megahertz (Mhz). The digital stream of information that is spread by the PN code is also known to the mobile stations. Because there is no ambiguity in the demodulated message, the timing characteristics of the PN code, down to the chip phase, as well as the QPSK modulation phase are known to the mobile station receiver.

The IS-95 system communicates information from the base station to the mobile stations through a series of traffic channels. These traffic channels are transmit and receive information, i.e. digitized audio signals, spread with a traffic channel PN code, unique to each mobile station. Using this precise timing and phase information derived from the

pilot channel, the mobile station is able to acquire a setup channel, and eventually, the overall System Time. With this System Time, the mobile station is able to differentiate between base stations and synchronize the demodulation circuitry with sufficient accuracy to recover the received  
5 traffic channel message.

A third generation, wideband CDMA (W-CDMA) system is in development as described in "Wideband-CDMA Radio Control Techniques for Third Generation Mobile Communication Systems", written by Once et al., IEEE 47<sup>th</sup> Vehicular Technology Conference Proceedings, May 1997,  
10 that may have global applications. Instead of a pilot channel, the W-CDMA system has a broadcast, or perch channel. Each timeslot, or slot of the broadcast channel consists of a series of time multiplexed symbols. A long code masked, or special timing symbol segment uses just a short code to spread one symbol of known information. This segment allows a mobile  
15 station to acquire system timing information immediately after turn-on. The pilot, or reference symbols are similar to the IS-95 pilot channel. In one proposal, 4 reference symbols, with each symbol being 2 bits, are spread with a long code and a short code. The reference symbol information and the short code are known by the mobile stations. The  
20 long code is unique to each base station, so that timing information is refined, once the long code is known (the base station is identified). Therefore, according to some proposals, 5 symbols in the slot would be dedicated to the mobile station acquiring timing information. Further, both the long and short codes spread 5 symbols of data during each slot.  
25 Since information is not predetermined for the data symbols, precise timing information cannot be accurately recovered, as with the other two

kinds of (timing) symbols. Other combinations of reference, special timing, and data symbols are also possible.

The W-CDMA system also includes several traffic channels to communicate information, such as a digitized voice or data. The traffic channel predominately includes information, but may also include a  
5 reference symbol segment. For example, at a data rate of 32 kilosymbols per second (ksps), a slot could include 4 pilot symbols and 16 information symbols. Precise timing information can be derived during the reference symbols segment of the traffic channel message, but not during the  
10 information segments.

The W-CDMA, or any spread spectrum system, operates best by minimizing the transmitted power of the users. Lower spectral power densities permit additional users to be added to the system, or an increase in the signal to noise ratio of received messages. Each mobile station is  
15 likely to receive more than one traffic channel from a base station, with each traffic channel being unique to a mobile station. That is, each base station is capable of transmitting hundreds of different traffic channels, the exact number is dependent on the traffic channel data rates. However, each base station transmits only a few, perhaps only one,  
20 broadcast channels that are used by all the receiving mobile stations. It is advantageous for the system that the base stations transmit the shared broadcast channels at a higher power level than the mobile station specific traffic channels. For this reason, the broadcast channel power is maintained at a relatively high level, while the traffic channel levels are  
25 continually monitored and adjusted to keep the transmitted power levels only as large as necessary to reasonably enable communication between the base station and the mobile.

Unlike the IS-95 system, the W-CDMA system does not use a master System Time to synchronize the base station transmissions. Each mobile station must independently acquire sufficient timing information regarding each base station to recover messages from that  
5 base station. The mobile station must simultaneously maintain timing information for multiple non-synchronously transmitting base stations.

Gilhousen, et al., U.S. Patent No. 5,109,390, disclose a spread spectrum receiver capable of differentiating multiple pilot signals and selecting the signal of greatest strength. The transmitting base  
10 stations are synchronized to operate from a master clock. Receiving mobile stations can maintain timing accuracy sufficient to demodulate received messages from all base stations by monitoring the pilot channel of any single base station. However, Gilhousen et al. do not disclose a method of conveniently receiving communications from asynchronously  
15 transmitting base stations.

Ling, U.S. Patent 5,329,547 discloses a method of inserting reference symbols into a stream of spread spectrum data symbols. The reference symbols help generate a channel estimate. That is, the insertion of predetermined data, or reference symbols into the data  
20 stream helps eliminate phase ambiguity in demodulating unknown data symbols. However, Ling does not disclose a method of synchronizing the timing between a plurality of received channels.

It would be advantageous if a W-CDMA receiver were developed to acquire the channels of a first asynchronously transmitting  
25 base station independent of the transmissions of other base stations. It would also be advantageous if the receiver could direct a plurality of base



stations to synchronize transmissions to take advantage of the diversity provided by receiving from several base stations.

It would be advantageous if the base station transmitted broadcast, or perch channel could be used by a mobile station to maintain  
5 timing for all channels received from that base station.

It would be advantageous if the amount of channel information present in the structure of a receiver multi-channel CDMA waveform was maximally utilized.

It would be advantageous if the broadcast channel in a W-  
10 CDMA system, generally having more transmitted power than the traffic channels and a greater number of reference symbols, could be used by a mobile station to demodulate the traffic channel.

It would be advantageous if the channel estimates derived from the broadcast channel could be applied to all the received channels of  
15 the same transmission path. In this manner, the channel estimate need be performed only once.

Accordingly, a method of receiving communications in a CDMA communication system, including a plurality of base stations asynchronously transmitting information to a plurality of mobile stations,  
20 is provided. The communications from a base station to a mobile station are formatted in a plurality of channels. Due to multipath, these communications are propagated along at least one transmission path, with a corresponding path delay. Each of these communications can be considered a family of related channels, so that families of channels  
25 propagate along the same transmission path. A method for each mobile station to receive base station communications comprises the steps of:

a) for each base station from which a communication is received, identifying at least one transmission path between a base station and the mobile station. Typically a mobile station is able to identify a base station communication along several transmission paths;  
5 and

b) in response to the transmission paths identified in Step a), despreding at least one received communication. That is, in an asynchronous system of transmissions, the mobile station is able to recover the data symbols in the communication in response to timing  
10 information recovered from locking the receiver onto any one of the multipathed base station transmissions.

Each base station transmission includes a broadcast channel message with a plurality of predetermined time multiplexed symbols, including a predetermined special timing symbol known to each mobile  
15 station. Step a) includes, for each transmission path identified in Step a), despreding the special timing symbol, whereby broadcast channel multiplex timing information is derived. Further steps include:

a<sub>1</sub>) in response to special timing symbol despread in Step a), calculating channel timing information for each transmission path  
20 detected in Step a); and

in which Step b) includes despreding received communications in response to the channel timing information calculated in Step a<sub>1</sub>).

The broadcast channel message includes time multiplexed  
25 data symbols, and predetermined time multiplexed reference symbols known to the mobile station. Step b) includes despreding the broadcast channel data and reference symbols. Initially, the channel timing is

found by despreding the special timing signal in Step a<sub>1</sub>). The timing is improved by despreding the reference symbols in Step b).

Each base station transmits at least one traffic channel message, unique to each mobile station. The traffic channel has a plurality of time multiplexed data symbols. Step b) includes despreding the traffic channel data symbols. Since the reference and data symbols for both the traffic and broadcast channels are modulated before transmission, the method of the present invention includes the further steps, following Step b), of:

10           c)     in response to the broadcast channel reference symbols despread in Step b), demodulating the broadcast channel reference symbols to provide transmission path weights and phase shift information;

15           d)     in response to the weights and phase shifts provided during the demodulation of the broadcast channel reference symbols, estimating weights and phase shifts to apply to data symbols; and

          e)     in response to estimations made in Step d), demodulating the broadcast and traffic channel data symbols.

Each traffic channel message includes predetermined time multiplexed reference symbols known to each mobile station, which are modulated before transmission. In some aspects of the invention, Step b) includes despreding the traffic channel reference symbols. Then, the traffic channel reference symbols are demodulated to provide transmission path weights and phase shift information. In addition, the weights and phase shifts provided from the demodulation of the traffic channel reference symbols are used to estimate weights and phase shifts to apply to the demodulation of the traffic channel data symbols.

Ultimately, the broadcast channel data symbols demodulated for each transmission path are combined in a RAKE receiver to improve the signal to noise ratio of a received message. This process occurs by combining the received transmissions of each base station.

5           A mobile station receiver to accept base station communications is provided. The receiver comprises at least a first filter matched to despread the broadcast channel special timing symbol. The first matched filter accepts the broadcast channel special timing symbol received for each transmission path from a communicating base station,  
10           and provides the despread special timing symbol for each transmission path.

          The receiver also comprises a timing and code management circuit connected to the first matched filter output to accept despread special timing symbols for each transmission path. The timing and code  
15           management circuit provides the despread broadcast channel special timing symbol for each transmission path, and a second output provides the broadcast channel multiplex timing information and base station identification for each transmission path.

          The receiver comprises a traffic channel RAKE receiver  
20           having a plurality of fingers. Each finger is operatively connected to the timing and code management circuit second output. Each finger uses the broadcast channel multiplex timing and base station identification information provided by the timing and code management circuit to  
          despread the traffic channel data symbols for each transmission path.  
25           The timing and coding needed to despread the traffic channel results from despreading the broadcast channel.

Each base station is assigned a unique long code, and the base stations transmit broadcast channel reference symbols spread with their long code. The mobile station's receiver further comprises a searcher unit to accept the broadcast channel reference symbols for each transmission path. A second searcher input, connected to the timing and code management circuit, accepts the despread broadcast channel special timing symbol for each transmission path. The searcher unit identifies the long code for the broadcast channel received on each transmission path, and provides the long code of the broadcast channel for each transmission path. The timing and code management circuit, connected to the searcher, accepts the broadcast channel long code for each transmission path. The timing and code management circuit second output provides broadcast channel long codes, as well as despread special timing symbols, for each transmission path.

The mobile station receiver further includes a broadcast channel RAKE receiver with a plurality of fingers, with each finger assigned to a received message transmission path. The broadcast channel RAKE receiver comprises a delay locked loop (DLL) to provide a clock at a first chip rate and a long code despread signal, which is the product of the long code times the channel messages of a transmission path. The DLL also despreads the broadcast channel message. A broadcast channel estimation and weighting circuit demodulates the broadcast channel reference symbols to determine the assigned transmission path weights and phase shifts, and to estimate weights and phase shifts to apply during the demodulation of broadcast and traffic channel information symbols. A first summing circuit combines the demodulated broadcast channel data symbols.

The receiver comprises a traffic channel RAKE receiver with fingers corresponding to the broadcast channel fingers having the same assigned transmission path. Each traffic channel RAKE receiver finger despreads and demodulates the traffic channel data symbols. A traffic channel estimation and weighting circuit accepts the despread traffic channel data symbols, and is connected to the broadcast channel estimation and weighting circuit to accept the estimated weights and phase shifts to aid in the demodulation of the traffic channel data symbols. In some aspects of the invention, the traffic channel estimation and weighting circuit also demodulates the traffic channel reference symbols to determine the assigned transmission path weights and phase shifts, and estimates the weights and phase shifts for application in the demodulation of traffic channel data symbols. Several second summing circuits, each second summing circuit being assigned the various transmission paths of one base station, combine the outputs of several traffic channel estimation and weighting circuits. A third summing circuit combines the results from each base station (each second summing circuit) to improve the quality of the received traffic channel message.

20 Brief Description of the Drawings

Fig. 1 is a schematic block diagram of the receiving system of the present invention.

Fig. 2 illustrates the broadcast and traffic channel message format and frame structure transmitted by a base station.

25 Fig. 3 illustrates the spreading codes assigned each mobile station during a slot, as defined in the timing diagram of Fig. 2.

Fig. 4 is a more detailed depiction of the delay locker loop (DLL) of Fig. 1.

Fig. 5 represents base station transmissions radiated through space, with multipath, to a mobile station.

5 Fig. 6 is a flow chart illustrating steps in a method for a mobile station to receive base station communications in accordance with the present invention.

Fig. 7 is a flow chart illustrating steps in a method for a mobile station to receive base station communications in accordance with  
10 an aspect of the present invention.

Fig. 8 is a flow chart illustrating the present invention's method for a mobile station to synchronize communications from at least two asynchronously transmitting base stations.

15 Detailed Description of the Preferred Embodiment

Fig. 1 is a schematic block diagram of the receiving system  
10 of the present invention. A code division multiple access (CDMA) communication network has a plurality of base stations (not shown) asynchronously transmitting information to a plurality of mobile stations.  
20 Each mobile station includes a receiver, such as receiver 10. The coded communications from a base station to a mobile station are formatted in a plurality of channels including a broadcast channel message and at least one traffic channel message (see Fig. 2). Typically, each mobile station receives a number of traffic and access channels from a base station, once  
25 communication has been established between the two users. Several types of channels are used in this system. Two channels of great importance are the perch and traffic channels (TCH). The perch channel

is a physical broadcast channel, i.e., a physical channel that is broadcast to users regardless of whether they have established other physical channels for communication. The perch channel comprises timing (reference) symbols, a pilot signal (special timing symbol) for channel estimation, and a logical broadcast channel (data symbols) designated as BCCH, used for the broadcast of system information. As suggested in some proposals, the perch channel could operate at 16 ksps, and the traffic channels (TCHs) at 32, 64, 128, 256, 512 and 1024 ksps. For the purposes of clarity and simplicity, only the receipt of a single broadcast channel and a single traffic channel is described below.

As is well known in the art, multipath typically exists between two users communicating with an RF carrier frequency. The multipath is caused as a signal "bounces" off geographical features or obstacles. To receive a transmission, each broadcast and traffic channel is propagated along at least one transmission path, with a corresponding path delay. In some systems, multipath is intentionally added with transmissions from the base station being radiated by two or more antennas. Multiple paths add robustness to the transmissions by creating alternate paths between users and the base station. A more detailed explanation follows in the description of Fig. 5.

Fig. 2 illustrates the broadcast and traffic channel message format and frame structure transmitted by a base station. The perch, or broadcast channel message depicted in slot 1, labeled with reference designator 12, includes predetermined time multiplexed reference, or pilot symbols 14 and a special timing, or long code masked symbol 16. The traffic channels message, labeled with reference designator 18, includes time multiplexed data symbols 20.



Returning again to Fig. 1, mobile station receiver 10 comprises at least a first filter 22 matched to despread the broadcast channel special timing symbol, see Fig. 2, reference designator 16. First matched filter 22 has an input on line 24 to accept the broadcast channel special timing symbol received for each transmission path from a communicating base station. First matched filter 22 has a first output on line 26 to provide the despread special timing symbol for each transmission path. In this manner, multiplex timing information for the broadcast channel is provided.

A timing and code management circuit 28, having a first input operatively connected to first matched filter 22 output on line 26, accepts despread special timing symbols for each transmission path. Timing and code management circuit 28 has a first output on line 30 to provide the despread broadcast channel special timing symbol for each transmission path, and a second output on line 32 to provide channel multiplex timing information and base station identification for each transmission path.

A traffic channel RAKE receiver 34, depicted with dotted lines, has a plurality of fingers. For the purposes of simplicity and clarity, only a single finger 36 is depicted in Fig. 1. However, the operation of the other traffic channel RAKE receiver fingers is the same as finger 36. Each finger, including finger 36, has an input operatively connected to timing and code management circuit 28 second output on line 32. Finger 36 uses the broadcast channel multiplex timing and base station identification information provided by timing and code management circuit 28 to despread the traffic channel data symbols (see Fig. 2, reference designator 20) for each transmission path. The timing and

codes needed to despread the traffic channel results from despreading the broadcast channel.

Fig. 3 illustrates the spreading codes assigned each mobile station during a slot, as defined in the timing diagram of Fig. 2. Each base station in the communications system is assigned a unique long code, and the base stations transmit broadcast channel reference symbols spread with their long code. The long code is represented by "left-leaning" hatched lines represented by reference designator 38. For a majority of the slot duration, including the time duration of reference symbols 14, broadcast channel message 12 is spread with long code 38. This duration of time is represented by reference designator 40.

Returning again to Fig. 1, receiver 10 further comprises a searcher unit 42 having a first input on line 24 to accept the broadcast channel reference symbols for each transmission path. That is, searcher 42 accepts all the multipath transmissions from a base station. Searcher 42 also accepts all transmissions from all received base stations. A second input is operatively connected to timing and code management circuit 28 first output on line 30 to accept the despread broadcast channel special timing symbol for each transmission path. Searcher unit 42 identifies the long code (see Fig. 3, reference designator 38) for the broadcast channel received on each transmission path. Searcher unit 42 has an output on line 44 to provide the long code of the broadcast channel for each transmission path. Since there are a limited number of long codes, searcher 42 is typically designed to test a series of stored codes against the received codes until a match occurs. In this manner, the base station is identified.

Timing and code management circuit 28 includes a second input on line 44 operatively connected to searcher unit 42 output on line 44 to accept the broadcast channel long code for each transmission path. The second output on line 32 provides broadcast channel long codes, as well as channel timing information, for each transmission path.

Each base station transmits broadcast and traffic channel messages modulated at a predetermined first chip rate, which is the rate at which the PN long code spreads a segment of information. Typically, the information, whether data bits or timing bits, is modulated with quadrature phase shift keying (QPSK), although biphase modulation is also possible. The rate of modulation need not match the rate of spreading, or the chip rate. For example, in some aspects of the invention the chip rate varies from approximately 1 to 16 megachips per second (Mcps), while the rate of modulation varies from 16 to 1024 kilosymbols per second (ksps), where one symbol equals two bits.

Returning to Fig. 3, the transmitted broadcast channel special timing symbol 16 is spread with just a predetermined first short code, represented by horizontal and vertical cross-hatched lines and reference designator 46. Since first short code 46 is common to, and known by all mobile stations, special timing symbol 16 is easily despread by first match filter 22, which is specifically designed to despread this code. During time duration 40, the broadcast channel reference symbols are spread with the long code 38 and a predetermined second short code represented by "right leaning" lines and reference designator 47. Traffic channel 18 data symbols (see Fig. 2, reference designator 20) are also spread with long code 38.

In Fig. 1, mobile station receiver 10 further includes a broadcast channel RAKE receiver 48, bounded by a dotted line. As with traffic channel RAKE 34, broadcast channel RAKE receiver 48 includes a plurality of fingers. Although only a single finger 50 is shown, the other  
5 fingers, not shown, operate equivalently to finger 50. Each finger, including finger 50, is assigned to a transmission path. Finger 50 of said broadcast channel RAKE receiver 48 comprises a delay locked loop (DLL) 52 having a first input operatively connected on line 32 to timing and code management circuit 28 second output. DLL 52 has a second input to  
10 accept broadcast and traffic channel messages on line 54, and an output on line 56 to provide the first chip rate clock signal.

Timing of the signals is derived by passing each of antenna signals on line 24 through short code (long code masked symbol) matched filter 22 and examining the peaks of the output. The derived timing is  
15 then sent to timing and code management block 28. Searcher unit 42 gets the timing from timing and code management block 28 and then searches for the long code of each path. The timing and the long codes are then sent to DLL 52 of finger 50, and other fingers (not shown) related to the same base station.

As mentioned above, each base station modulates the  
20 transmitted data and reference symbols. In Figs. 2 and 3, broadcast channel message 12 includes five data symbols 70 being spread by the long code 38 and the second short code 47. Typically, the receiver system is operated with an available bandwidth of 5 MHz. The chip rate of the  
25 pseudonoise sequence for spreading the signal is 4.096 Mcps. The symbol rates that are supported by the system are 32, 64, 128, 256, 512 and 1024 kbps. The modulation method used for both data and spreading is QPSK.

Returning to Fig. 1, DLL 52 has a second output on line 58 to provide the despread broadcast channel data and reference symbols. As is well known in the art, the broadcast channel message is despread by multiplying the long code and the second short code by the received broadcast message of the assigned transmission path. During the time of the special timing symbol (reference designator 16, in Fig. 2), the broadcast channel message is despread by multiplying first short code 46 by the received transmission path channel message. Typically, second short code 47 is a simple pattern, such as all "1"s, so that the generation of these codes in DLL 52 is simplified.

A broadcast channel estimation and weighting circuit 60 has an input on line 58 operatively connected to DLL 52 second output to receive the despread broadcast channel reference and data symbols. Broadcast channel estimation and weighting circuit 60 demodulates the broadcast channel reference symbols (see Fig. 2, reference designator 14) to determine the assigned transmission path weights and phase shifts, and to estimate weights and phase shifts to apply during the demodulation of broadcast and traffic channel data symbols. Broadcast channel finger estimation and weighting circuit 60 has a first output to provide the demodulated broadcast channel data symbols, and a second output to provide weight and phase shift estimations for use with the traffic channel of the assigned transmission path.

At this point in the receiving process, the long code, first short code, second short code, and the chip rate clock have been generated in finger 50, and compared to the actual received message on line 54. During the time of the special timing symbol and reference symbols (see Fig. 2, reference designators 14 and 16, respectively) the demodulated

information is known to receiver 10. This timing knowledge permits estimation and weighting circuit 60 to determine the channel gain and phase variations of the despread, but still modulated message, with the QPSK demodulator estimation and weighting circuit 60. With this  
5 information, the relative signal strength and phase shift of the transmission path is measured and the transmission path is assigned a gain in response.

Likewise, the transmission path is assigned a phase shift. These weights and phase shifts are estimated during the time of the  
10 reference and special timing symbols. This knowledge permits estimation and weighting circuit 60 to estimate the weights and phase shifts for application to the transmission path when broadcast channel data symbols, not already known, are received.

In one aspect of the invention, weights and phase shifts,  
15 applied during the demodulation of broadcast and traffic channel data symbols are interpolated from the known weights and phase shifts. In other aspects, the weights and delays are extrapolated. Interpolation and extrapolation will be discussed more fully, below.

Finger estimation and weighting circuit 50 has a first output  
20 on line 62 to provide the demodulated broadcast channel data symbols, and a second output on line 64 to provide weight and phase shift estimations for use with the traffic channel of the assigned transmission path.

As suggested in some proposals, the perch channel uses the  
25 code denoted as  $C_p(0)$ , which is all 1's, as the common second short code, the long code despread signal is essentially the perch channel despread signal for the duration during which the long code is not masked. DLL 52

has a third output on line 66 to provide the long code despread signal, which is a product of the long code multiplied by the broadcast and traffic channel messages.

The long code despread signal is also further despread by the  
5 respective short codes to obtain the signal on various channels. The despread signal is then passed through RAKE estimation and weighting circuit 60 to obtain "soft" decisions that are used in decoding the signal. Soft decisions are an output that have not been quantized, but must still be decoded by an forward error correction (FEC) decoder. Broadcast  
10 channel estimation and weighting circuit 60 in the perch channel has substantially the same function as the RAKE estimation and weighting circuit in the traffic channel (presented below).

Fig. 4 is a more detailed depiction of DLL 52 of Fig. 1. The received channels are input into DLL 52 on line 54, to drive first mixer 68  
15 and second mixer 73. A second short code generator (2<sup>nd</sup> SCG) 71 also drives first mixer 68 with a signal on line 72, so that first mixer 68 has an output on line 74. Likewise, a long code generator (LCG) 76 drives second mixer 73 with a signal on line 78, so that second mixer 73 has an output on line 66. The output on line 66 is the long code despread signal  
20 exported from DLL 52 on line 66. The long code despread signal on line 66 and the second short code on line 72 drive third mixer 80 and produce the despread broadcast channel data and reference symbols on line 58.

The short code despread signal on line 74, the long code despread signal on line 66, and the first code on line 82 (which is  
25 generated either internal or external to DLL 52) are input to chip phase detector (CPD) 84. In some aspects of the invention second short code generator 71 outputs the first short code on line 72 during the time of the

special timing symbol so that line 82 is eliminated. The output of CPD 84 on line 85 is input to loop filter 86. The output of loop filter 86 on line 87, along with the timing information on line 32, is input into numerically controlled clock (NCC) 88 to generate the clock signal at the first chip rate  
5 on line 56. The clock signal on line 56 is fed back to second short code generator 71 and long code generator 76 to maintain the correct phase relationship between the channel messages on line 54 and the generation of the codes.

A first summing circuit 90 has a plurality of inputs on lines  
10 62, 62a, and 62b operatively connected to said broadcast channel estimation and weighting circuit 60 first output of each broadcast channel RAKE receiver finger, such as finger 50. That is, all the fingers of perch RAKE receiver 48, assigned to all transmission paths, are combined. Since the broadcast channel data symbols are the same for all base  
15 stations, there is no need to segregate transmission paths by base station. Dotted lines 62a and 62b represent connections to two other broadcast channel fingers (not shown). A plurality of fingers, typically six or less, are thus summed. First summing circuit 90 combines the demodulated broadcast channel data symbols to provide an output on line 92 with  
20 demodulated broadcast channel data symbols having an improved signal to noise ratio. Multipath broadcast channel messages from all sources are combined.

Returning to Fig. 3, each base station assigns a third short code, represented by horizontal lines 94, which is unique for each mobile  
25 station, to each mobile station. Transmitted traffic channel data symbols 20 are spread with third short code 94, as well as long code 38.



In Fig. 1, each finger of traffic channel RAKE receiver 34 corresponds to a finger of broadcast channel receiver 48 having the same assigned transmission path. That is, broadcast channel RAKE finger 50 is assigned to the same transmission path as traffic channel RAKE finger 36. Traffic channel RAKE receiver finger 36 comprises a traffic channel short code generator (TC SCG) 96 to generate the third short code, having an input on line 56 operatively connected to DLL 52 first output to accept the first chip rate clock signal. Traffic channel short code generator 96 has an output on line 98 to provide the mobile station's assigned third short code at a rate matching the traffic channel message received on that transmission path.

A traffic channel mixer 100 has a first input operatively connected on line 98 to traffic channel short code generator 96 output, and a second input is operatively connected on line 66 to DLL 52 third output in corresponding broadcast channel finger 50, to accept the long code despread signal. Traffic channel mixer 100 has an output on line 102 to provide the despread traffic channel data symbols.

Traffic channel finger 36 further comprises a traffic channel estimation and weighting circuit 104 having a first input on line 102 operatively connected to the output of traffic channel mixer 100 to accept the despread traffic channel data symbols. A second input on line 64 is operatively connected to broadcast channel estimation and weighting circuit 60 second output in corresponding broadcast channel finger 50. Traffic channel estimation and weighting circuit 104 accepts the estimated weights and phase shifts from broadcast channel estimation and weighting circuit 60 to aid in the demodulation of the traffic channel data symbols. Traffic channel finger estimation and weighting circuit 104

has a first output on line 106 to provide the demodulated traffic channel data symbols. The heart of the present invention is the use of the broadcast channel timing information to demodulate the traffic channel. Since receiver 10 is likely to be receiving several other channels

5 simultaneously with the traffic channel, the use of a single channel to time other channels transmitted from the same base station, or even multiple base stations, results in a considerable savings of hardware and computation time. Further, the use of the relatively high power broadcast channel results in timing relationships that are based on information

10 having a higher signal to noise ratio.

In some aspects of the invention, traffic channel estimation and weighting circuit 104 demodulates the traffic channel reference symbols (see Fig. 3, reference designator 105) to determine the assigned transmission path weights and phase shifts, and estimates the weights

15 and phase shifts for application in the demodulation of traffic channel data symbols. Using the reference symbols of the traffic channel to augment timing relationships derived from the broadcast channel, results in increased channel estimation accuracy at the expense of additional hardware.

20 A second summing circuit 108 has a plurality of inputs operatively connected with lines 106, 106a, and 106b to traffic channel estimation and weighting circuit output of each traffic channel RAKE receiver finger for a transmitting base station group. That is, only the traffic channel estimates from a single base are summed in second

25 summing circuit 108. Unlike the broadcast channel, the traffic channels of different base stations cannot be simply summed. The traffic channel data symbols from different base stations are not the same. The

difference is in the transmit power control (TPC) bit. This bit is a base station request to set or change the transmitting power level of the mobile station. It is possible for a first base station to request an increase in power, while a second base station requests a decrease, and in a mobile station response to one of the base station requests, a loss of communication with the other base stations results. Once the TPC bit is removed from the traffic channel data, the data from several base station is summed, as presented below.

Line 106 is shown operatively connecting estimation and weighting circuit 104 and second summing circuit 108. Other fingers (not shown) are represented by dotted lines 106a and 106b. Second summing circuit 108 has an output on line 110 to provide the sum of the demodulated traffic channel data symbols for each transmission path from a (the same) base station, whereby the signal to noise ratio of the received information is improved by combining signals of each transmission path.

Fig. 5 represents base station transmissions radiated through space, with multipath, to a mobile station 120. Mobile station 120 has two antennas, first antenna 122, and second antenna 124. Mobile station 120 is receiving communications from two base stations, first base station 126, and second base station 128. Multipath between second base station 128 and mobile station first antenna 122 is shown with transmission path A, represented by reference designator 151, and transmission path B, represented by reference designator 152. Multipath between first base station 126 and mobile station second antenna 124 is shown with transmission path C, represented by reference designator 153, and transmission path D, represented by reference designator 154. Figure 4 also presents the concept of diversity, i.e., where first base

station 126 communicates to mobile station 120 through transmission path D 154 to second antenna 124, and through transmission path E 155 to first antenna 122. For the purposes of simplicity and clarity, only two base stations are shown, although mobile station 120 potentially receives  
5 communications from a plurality of base stations (not shown).

Receiver 10 of mobile station 120 further comprises first antenna 122 having an input to accept the radiated transmissions of base stations 126 and 128. Returning to Fig. 1, first antenna 122 has an output on line 24 operatively connected to receiver 10 through down-  
10 conversion circuitry (not shown) to provide broadcast and traffic channel messages in the form of a baseband signal that is the input to first matching filter 22. Likewise, second antenna 124 has an input to accept the radiated transmissions of base stations 126 and 128, and an output on  
15 line 140 operatively connected to receiver 10 to provide broadcast and traffic channel messages in the form of a down-converted baseband signal. Not shown is an automatic frequency control (AFC) circuitry to compensate the receiver RF carrier frequency for frequency drift in local oscillators (not shown) of receiver 10.

In Fig. 1, receiver 10 comprises a second filter 142 matched  
20 to despread the broadcast channel special timing symbol. Second matched filter 142 has an input operatively connected to second antenna 124 output on line 140 to accept the broadcast channel special timing symbols received for each transmission path from a base station to second antenna 124, and a first output on line 144 to provide the despread special timing  
25 symbols for each transmission path, whereby a timing pulse is provided.

First matched filter 22 input is operatively connected on line 24 to first antenna 122 output to accept the broadcast channel special

timing symbols received for each transmission path from a base station to first antenna 122.

Timing and code management circuit 28 includes a third input operatively connected on line 144 to second matched filter 142 output. Broadcast channel RAKE receiver finger 50 includes a switch 146, having a first input operatively connected on line 24 to first antenna 122 output. Switch 146 has a second input operatively connected on line 140 to second antenna 124 output, and an output operatively connected on line 54 to DLL 52 second input to selectively supply the broadcast channel message from alternate antennas 122 and 124. The diversity of two antennas is used to increase the signal to noise ratio of the demodulated messages.

As shown in Fig. 5, mobile station 120 often receives communications from at least two base stations 126 and 128. As mentioned above with the discussion of second summing circuit 108, traffic channel RAKE receiver finger, such as finger 36, are grouped by transmitting base station. A logic unit 130 operatively connected to the receiver with line 92, receives broadcast channel multiplex timing information from first summing circuit 90 of broadcast channel RAKE receiver 48. A comparison of the broadcast channel timing information from the at least two base stations is made in logic unit 130. Logic unit 130 has an output on line 132 to provide a message requesting a timing adjustment to the traffic channel transmission of at least one base station.

A transmitter 134 has an input operatively connected to the logic unit output on line 132 to receive traffic channel timing requests. Transmitter 134 has an output on line 136, through duplexers 138 and 139, to transmit messages to base stations 126 and 128. Typically,

receiver 10 makes such a request when communication between receiver 10 and a base station is initially established, so that the timing relationships are set for the duration of the communications. Alternately, the timing is adjusted in response to mobile station communications with other base stations, doppler effects, and propagation delays.

Returning to Fig. 1, in some aspects of the invention, second summing circuit 108 is a plurality of summing circuits, although for the purpose of clarity only one summing circuit 108 is shown. The outputs of two such additional second summing circuits are represented by dotted lines 110a and 110b. Each second summing circuit 108 is assigned to a different base station to sum the multipathed traffic channel data symbols of a selected base station.

A third summing circuit 148 has a plurality of inputs, lines 110, 110a, and 110b are shown in Fig. 1, operatively connected to second summing circuits 108 (and other second summing circuits not shown). A greater or lesser number of lines are input into third summing circuit 148 in other aspects of the invention. An output on line 150 provides the sum of the traffic channel data symbols of different transmitting base stations. The traffic channel symbols from multiple base stations are summed for an enhanced signal to noise ratio signal.

To increase to data rate of a received signal, in some aspects of the invention a plurality of traffic channel RAKE circuits, such as traffic channel RAKE 34 are operated in parallel to receive, despread and demodulate a plurality of traffic channels. For the purpose of clarity these additions traffic channel RAKEs are not shown in Fig. 1, but their operation is the same as traffic channel RAKE 34.

To obtain the soft decisions, RAKE estimation and weighting circuits 80 and 104 of all the channels need the channel coefficients. All the channels have pilot symbols which can be used to estimate the channel coefficients. The pilot, or special timing symbols within each of the channels can be used to estimate the coefficients for that channel.

The channel parameters are estimated by multiplying the known pilot symbols with the received signal corresponding to the pilot symbols. Then, these parameters are interpolated to obtain an estimate of the channel parameters during the unknown symbol transmission.

To be more specific, let the received signal be despread and resolved into  $L$  path components. Let the number of pilot symbols in one slot be  $P$ . Without loss of generality, it is assumed that the detection is performed on the symbols in the  $k^{\text{th}}$  slot. Let the sampled despread signal be  $r_{d,l}(m + kN)$ , at time  $t = mT$ , for the  $m^{\text{th}}$  symbol in the slot for the  $l^{\text{th}}$  path ( $l = 0, \dots, L-1; m = 0, \dots, N-1$ ), where  $N$  is the number of symbols in a slot. Assuming that a pilot symbol is  $p(k, m)$ , the channel estimate during the pilot symbol transmission ( $m = 0, \dots, P-1$ ) is

$$c_{d,l}(m + kn) = (p^*(k, m)r_{d,l}(m + kn))/2 \quad (1)$$

20

To compute the channel estimates, we first compute the following refined estimate:

$$\mathcal{E}_{d,l,k} = \sum_{m=0}^{P-1} c_{d,l}(m + kn) \quad (2)$$

25

The faded complex envelope at the coded data symbol position at  $t = mT$ ,  $m = P, \dots, N - 1$  is then estimated by the first order interpolation and is given by,

$$5 \quad \varphi_{d,l}(m + kn) = (1 - (m - (P - 1)/2)/N)\varepsilon_{d,l,k} + ((m - (P - 1)/2)/N)\varepsilon_{d,l,k+1} \quad (3)$$

detection is achieved by multiplying the despread signal with the corresponding complex conjugate of the channel estimate based on the above expression. Thus, the output of the RAKE combiner for the  $m^{\text{th}}$  symbol in the slot would be given by

$$10 \quad r(m) = \sum_{l=0}^{L-1} r_{d,l}(m + kn) \varphi_{d,l}^*(m + kn) \quad (4)$$

$$15 \quad m = P, \dots, N - P - 1$$

This output sample is then decomposed into the real and imaginary components. Hard decisions are made on these components and are associated with the first and second bits of the  $m^{\text{th}}$  QPSK symbol in the slot. The estimate performed using equation 3, however, contains the noise of frequencies of up to the symbol rate. Since the doppler frequencies that vary the channel are far below any symbol rate, the estimates can be smoothed. To this end, the refined estimates in equation 2 are smoothed by a low-pass filter whose cut-off frequency is higher than the Doppler rate. Interpolation proceeds based on equation 4.

The procedure described above can be done on each of the channels to get the channel estimates. However, a repetition of



procedures is avoided if channel estimation is done only on one single channel, and the estimate then used for decoding other channels. Since the perch channel typically has power that is significantly higher than the other channels, and pilot symbols of a longer duration than any other channels, it is the ideal choice.

While performing the channel estimation from the perch channel for application to other channels, the estimate given in equation 2 cannot be used directly. This is because the frame in the perch channel is not synchronized with the frame in the traffic channel. Consequently, there will be a delay of  $\Delta$  between the slot boundaries for the two channels. Further, the quantity in equation 2 is computed for the time instant  $((RP - 1)/2)T - \Delta$  in each slot for the perch channel, where R is the ratio of symbol rate on the perch channel to the symbol rate on the traffic channel. Thus, the computation in equation 3 should be changed to

$$\varphi_{d,l}(m + kn) = (1 - \tau)\mathcal{E}_{d,l,k} + \tau\mathcal{E}_{d,l,k+1} \tag{5}$$

where

$$\tau = (m - (RP - 1)/2)/N - (\Delta/T) \tag{6}$$

where longer delays in channel estimation are tolerable, traffic channel data is interpolated. That is, the traffic channel weights are formed in response to weights from the present slot's perch channel pilot symbols, and the succeeding slot's perch channel pilot symbols, as represented below:

$$w_{traffic} = a(w\{n\}) + b(w\{n+1\}) \tag{7}$$

where  $w_{\text{traffic}}$  is the traffic channel weight at the  $n^{\text{th}}$  instant of time,  $w[n]$  is the channel weight derived from the perch channel at the  $n^{\text{th}}$  instant, and  $a$  and  $b$  are constants. For certain data, such as the TPC bit, extrapolation is used, as represented below:

5

$$w_{\text{power control}} = a(w[n]) + b(w[n-1]) \quad (8)$$

where  $w_{\text{traffic}}$  is the channel weight for the power control symbols at the  $n^{\text{th}}$  instant of time,  $w[n]$  is the channel weight derived from the broadcast channel at the  $n^{\text{th}}$  instant of time, and  $a$  and  $b$  are constants. Both interpolation and extrapolation procedures are extended to do polynomial fits of channel estimates over multiple slots, in some aspects of the invention.

For the decoding of certain symbols, like TPC, the decoding needs to be done before the next slot estimation can be performed. In such situations, extrapolation needs to be performed. Also, in some other functions like AFC, waiting for the next slot would increase the transport delay. Again, to minimize this delay, extrapolation needs to be performed.

As shown in Fig. 2, a radio frame of 10 milliseconds (ms) is divided into 16 slots. Broadcast and traffic channel messages are organized into a series of time multiplexed slots. Broadcast and traffic channel RAKE receivers 80 and 104 estimate weights and phase shifts to apply to the demodulation of the traffic channel data symbols through an interpolation process using the weight and phase shift estimates from present, as well as succeeding slots.

As presented above, and shown in traffic channel 18 of Fig. 2, the traffic channel data symbols include at least one transmit power

control (TPC) bit. Broadcast and traffic channel RAKE receivers estimate weights and phase shifts to apply to the demodulation of the TPC bit through an extrapolation process using the weight and phase shift estimates from present, as well as previous slots.

5           Fig. 6 is a flow chart illustrating steps in a method for a mobile station to receive base station communications in accordance with the present invention. Step 160 provides a code division multiple access (CDMA) communication system including a plurality of base stations asynchronously transmitting information to a plurality of mobile stations. 10 The communications from a base station to a mobile station are formatted in a plurality of channels and propagated along at least one transmission path, with a corresponding path delay. Step 162, for each base station from which a communication is received, identifies at least one transmission path between a base station and the mobile station. Step 15 164, in response to the transmission paths identified in Step 162, despreads at least one received communication. Step 166 is a product, a receiver where multipath timing analysis is used in despreading data.

In some aspects of the invention, Step 160 provides that each base station transmission include a broadcast channel message with a 20 plurality of time multiplexed symbols, including a predetermined special timing symbol known to each mobile station. Then, Step 162 includes, for each transmission path identified in Step 162, despreading the special timing symbol, whereby broadcast channel multiplex timing information is derived. A further step, following Step 162, is included. Step 162a, in 25 response to special timing symbol despread in Step 162, calculates channel timing information for each transmission path detected in Step

162. Then, Step 164 includes despreading received communications in response to the channel timing information calculated in Step 162a.

Step 160 provides a transmitted broadcast channel message which includes time multiplexed data symbols and predetermined time multiplexed reference symbols known to the mobile station. Then, Step 5 164 includes despreading the broadcast channel data and reference symbols.

Step 160 provides that each base station transmit at least one traffic channel message, unique to each mobile station. The traffic 10 channel has a plurality of time multiplexed data symbols. Step 164 includes despreading the traffic channel data symbols.

Step 160 provides that the reference and data symbols for both the traffic and broadcast channels be modulated before transmission. Further steps, following Step 164, are then included. Step 164a, in 15 response to the broadcast channel reference symbols despread in Step 164, demodulates the broadcast channel reference symbols to provide transmission path weights and phase shift information. Step 164b, in response to the weights and phase shifts provided during the demodulation of the broadcast channel reference symbols, estimates 20 weights and phase shifts to apply to data symbols. Step 164c, in response to estimations made in Step 164b, demodulates the traffic channel data symbols.

In some aspects of the invention, Step 160 provides that each traffic channel message include predetermined time multiplexed 25 reference symbols known to each mobile station, which are modulated before transmission. Then, Step 164 includes despreading the traffic channel reference symbols. Further steps, following Step 164a, are

included, but not shown. Step 164a<sub>1</sub>, in response to the traffic channel reference symbols despread in Step 164, demodulates the traffic channel reference symbols to provide transmission path weights and phase shift information. Step 164b<sub>1</sub>, in response to the weights and phase shifts  
5 provided from the demodulation of the traffic channel reference symbols, estimates weights and phase shifts to apply to the traffic channel data symbols. Then, Step 164c includes demodulating the traffic channel data symbols in response to the weights and phase shifts estimated in Step 164b<sub>1</sub>.

10 In some aspects of the invention further steps, following Step 164c, are included. Step 164d (not shown), in response to estimations made in Step 164b, demodulates the broadcast channel data symbols. Step 164e (not shown), for all base stations, combines the broadcast channel data symbols demodulated in Step 164d for each transmission  
15 path identified in Step 162, whereby the signal to noise ratio of a received message is improved. Following Step 164c, Step 164f combines the traffic channel data symbols demodulated in Step 164c for each transmission path identified in Step 162, whereby the signal to noise ratio of a received message is improved.

20 Step 160 provides that the transmitted broadcast channel data and reference symbols are spread with a predetermined long code, unique to each base station. Then, Step 162 includes identifying the long code used to spread the broadcast channel message received on each transmission path, whereby a base station is identified. Step 164 includes  
25 generating the long code identified in Step 162 to despread the broadcast channel reference and data symbols, and the traffic channel reference and data symbols.

Step 160 provides that each base station spread the broadcast channel special timing symbol with only a predetermined first short code, and that each mobile station have at least a first matched filter to despread the first short code. Step 162a includes the despreading  
5 of every received broadcast channel special timing symbol to yield the identification of distinct transmission paths in Step 162.

Step 160 provides that each mobile station include a second matched filter, with the first matched filter operatively connected to a first antenna and the second matched filter operatively connected to a  
10 second antenna. Then, Step 162 includes the identification of transmissions paths from the base station to each of the mobile station antennas, whereby the diversity of the mobile station receiver is enhanced with the use of independent transmission paths.

Step 160 provides that the broadcast channel data and  
15 reference symbols are spread with a predetermined second short code, and the transmitted broadcast and traffic channel messages are modulated at a first chip rate. Step 160 also provides that the mobile station include a broadcast channel RAKE receiver with a plurality of fingers. Then, Step  
20 164 assigns a broadcast channel RAKE receiver finger to each transmission path identified in Step 162 to generate short and long codes, and in response to generated short and long codes, generates a clock signal at the first chip rate. The chip rate is generated for use by every channel of the assigned transmission path.

Step 160 provides that each base station assign each mobile  
25 a third short code, unique to each mobile station. The base station spreads the traffic channel message to a mobile station with its assigned third short code. Each mobile station includes a traffic channel RAKE

receiver with a plurality of fingers. Step 164 includes multiplying the broadcast channel data and reference symbols by the long code to generate a long code despread signal. Step 164 is divided into sub-steps. Sub-step 164<sub>1</sub>, for each transmission path identified in Step 162, identifies  
5 the transmitted traffic channel messages spread with the mobile station's third short code. Sub-step 164<sub>2</sub>, for each transmission path identified in Step 162, assigns a traffic channel RAKE receiver finger to the corresponding broadcast channel RAKE receiver finger assigned in Step 164. Sub-step 164<sub>3</sub>, in response to the first chip rate clock signal  
10 generated in Step 164, generates the third short code. Sub-step 164<sub>4</sub> multiplies the long code despread signal generated in Step 164 by the third short code generated in Sub-step 164<sub>3</sub>, to completely despread the traffic channel message.

In some aspects of the invention Step 160 provides that each  
15 mobile station includes a transmitter. Then, Step 162 includes receiving communications from at least two base stations, a first base station and a second base station. Step 162 includes identifying at least one transmission path between each base station and the mobile station. Further steps (not shown), follow Step 164. Step 164g, in response to the  
20 despreading of the broadcast channel of the first base station, transmits a request to the second base station to adjust the timing of the traffic channel transmission, whereby the timing differences between the first and second base stations are minimized. Step 164h receives the adjusted traffic channel transmission of the second base station, and Step 164i, in  
25 response to Step 164f, sums the combined traffic channel demodulated data symbols for the first and second base station, whereby diversity is increased with the use of two base stations.

Step 160 includes the broadcast and traffic control messages being organized into a series of time multiplexed slots. Step 164b includes broadcast and traffic channel RAKE receivers estimating weights and phase shifts to apply, to the demodulation of traffic channel data symbols in Step 164c, through an interpolation process using the weight and phase shift estimates from present, as well as succeeding slots. In other aspects of the invention, Step 160 includes the traffic channel data symbols including a transmit power control (TPC) bit. Step 164c includes demodulating the TPC bit with the traffic channel data symbols, and Step 164b includes broadcast and traffic channel RAKE receivers estimating weights and phase shifts, to apply to the demodulation of the TPC bit in Step 164c, through an extrapolation process using the weight and phase shift estimates from present, as well as previous slots.

Fig. 7 is a flow chart illustrating steps in a method for a mobile station to receive base station communications in accordance with an aspect of the present invention. Step 170 provides a code division multiple access (CDMA) communication system having a plurality of base stations asynchronously transmitting to a plurality of mobile stations. The communications from a base station to a mobile station being formatted in a plurality of coded channels including a broadcast channel message propagating along at least one transmission path, with a corresponding path delay. The broadcast channel message includes predetermined time multiplexed reference and special timing symbols. Step 172 despreads at least one broadcast channel special timing symbol. Step 174 identifies a transmission path in response to each broadcast channel special timing symbol despread in Step 172. Step 176 despreads the broadcast channel reference symbols for each transmission identified



in Step 174. Step 178, in response to the broadcast channel reference symbols despread in Step 176, identifies at least one base station from which transmissions are being received. Step 180 is a product, a method of receiving asynchronous base station messages where the codes and  
5 timing for each communicating base station are derived by the mobile station.

In some aspects of the invention, Step 170 provides that each base station transmit at least one traffic channel message, unique to each mobile station. Each traffic channel message includes time multiplexed  
10 data symbols. Further steps, following Step 178, are included. Step 178a, in response channel timing determined in Step 172, and the base station identification made in Step 178, despreads the broadcast and traffic channel messages for each transmission path identified in Step 174. Step  
15 178b, in response to the broadcast channel reference symbols despread in Step 178a, demodulates the broadcast channel reference symbols. Step 178c, in response to Step 178b, interpolates weights and phase shifts for demodulating the traffic channel data symbols. Step 178d, for each base station identified in Step 178, combines the traffic channel data symbols  
20 demodulated from each transmission path identified in Step 174, with the weights and phase shifts interpolated in Step 178c, whereby the signal to noise ratio of a base station transmission is improved.

Step 170 provides that the traffic channel include predetermined time multiplexed reference symbols. Then Step 178a includes despreading the traffic channel reference symbols, Step 178b  
25 includes demodulating the traffic channel reference symbols, and Step 178c includes interpolating weights and phase shifts in response to the demodulated traffic channel reference symbols.

Fig. 8 is a flow chart illustrating the present invention's method for a mobile station to synchronize communications from at least two asynchronously transmitting base stations. Step 200 provides a code division multiple access (CDMA) communication system having a plurality of base stations asynchronously communicating to a plurality of mobile stations. The communications from a base station to a mobile station being formatted in a plurality of coded channels including a broadcast channel message and a traffic channel message propagating along at least one transmission path, with a corresponding path delay.

5 The broadcast channel message includes predetermined time multiplexed reference and special timing symbols, and the traffic channel includes time multiplexed data symbols.

Step 202 despreads at least one broadcast channel special timing symbol from each base station. Step 204 establishes the broadcast channel multiplex timing for a transmission path, in response to each broadcast channel special timing symbol despread in Step 202. Step 206 despreads the broadcast channel reference symbols for each transmission path identified in Step 204. Step 208, in response to the broadcast channel reference symbols despread in Step 206, identifies at least two base stations from which transmissions are being received.

15

20

Step 210 demodulates the broadcast channel reference symbols for each transmission path identified in Step 204. Step 212, in response to the broadcast channel reference symbols demodulated in Step 210, refines the broadcast channel multiplex timing established in Step 204. Step 214 compares the broadcast channel timing, refined in Step 210 from at least two base stations. Step 216, in response to the comparison made in Step 214, transmits a request to one of the at least two base

25

stations to adjust its transmission of the traffic channel. Step 218 is a product, a received communication where the delay between the transmissions of traffic channels by different base stations is minimized.

Following Step 206, are further steps (not shown). Step 216a  
5 completely despreads the traffic channel messages for each transmission path identified in Step 204. Step 216b demodulates the traffic channel data symbols. Step 216c, for each base station identified in Step 208, combines the traffic channel data symbols demodulated in Step 216b. Step 216d sums the traffic channel data symbols combined in Step 216c  
10 for all the base stations identified in Step 208, whereby the signal to noise ratio of the received message is enhanced from the diversity of combining each transmission path, as well as each base station.

A receiver system and method is provided to use timing information gleaned from demodulating the perch channel, directly in the  
15 despreading and demodulation of the traffic channel. Although a traffic channel has been specifically cited, the principle of deriving all timing relationships from the perch channel is applicable to the demodulation of other channels. The perch channel generally has a higher power level and greater density of reference symbols, and it saves hardware and processor  
20 time to base all channel timing relationships on just one reference channel. Further, the perch channel is used to adjust the timing of base station traffic channel transmissions so that the same information is received from different base stations at approximately the same time. Other embodiments of the present invention will occur to those skilled in  
25 the art.

## CLAIMS

1. In a code division multiple access (CDMA) communication system including a plurality of base stations asynchronously transmitting information to a plurality of mobile stations, the communications from a base station to a mobile station being  
5 formatted in a plurality of channels propagated along at least one transmission path, with a corresponding path delay, a method for each mobile station to receive base station communications comprising the steps of:
  - a) for each base station from which a communication is  
10 received, identifying at least one transmission path between a base station and the mobile station; and
  - b) in response to the transmission paths identified in Step a), despreading at least one received communication, whereby the multipath timing analysis is used in despreading data.
  
2. A method as in claim 1 wherein each base station transmission includes a broadcast channel message with a plurality of time multiplexed symbols, including a predetermined special timing symbol known to each mobile station, in which Step a) includes, for each  
5 transmission path identified in Step a), despreading the special timing symbol, whereby broadcast channel multiplex timing information is derived, and including the further step, following Step a), of:
  - a<sub>1</sub>) in response to special timing symbol despread in Step  
a), calculating channel timing information for each transmission path  
10 detected in Step a); and

in which Step b) includes despreading received communications in response to the (channel timing information) calculated in Step a<sub>1</sub>).

3. A method as in claim 2 wherein the broadcast channel message includes time multiplexed data symbols and predetermined time multiplexed reference symbols known to each mobile station, and in which Step b) includes despreading the broadcast channel data and reference  
5 symbols.

4. A method as in claim 3 wherein each base station transmits at least one traffic channel message, unique to each mobile station, wherein the traffic channel has a plurality of time multiplexed data symbols, and in which Step b) includes despreading the traffic  
5 channel data symbols.

5. A method as in claim 4, wherein the reference and data symbols for both the traffic and broadcast channels are modulated before transmission, and including the further steps, following Step b), of:

c) in response to the broadcast channel reference symbols  
5 despread in Step b), demodulating the broadcast channel reference symbols to provide transmission path weights and phase shift information;

d) in response to the weights and phase shifts provided during the demodulation of the broadcast channel reference symbols,  
10 estimating weights and phase shifts to apply to data symbols; and

e) in response to estimations made in Step d),  
demodulating the traffic channel data symbols.

6. A method as in claim 5 wherein each traffic channel message includes predetermined time multiplexed reference symbols known to each mobile station, which are modulated before transmission, in which Step b) includes despreading the traffic channel reference symbols, and including the further steps, following Step c), of:

5 c) in response to the traffic channel reference symbols despread in Step b), demodulating the traffic channel reference symbols to provide transmission path weights and phase shift information;

d) in response to the weights and phase shifts provided

10 from the demodulation of the traffic channel reference symbols, estimating weights and phase shifts to apply to traffic channel data symbols; and

in which Step e) includes demodulating the traffic channel data symbols in response to the weights and phase shifts estimated in

15 Step d).

7. A method as in claim 5 including the further step, following Step d), of:

f) in response to estimations made in Step d), demodulating the broadcast channel data symbols; and

5 g) combining the broadcast channel data symbols demodulated in Step f) for each transmission path identified in Step a), whereby the signal to noise ratio of a received message is improved.

8. A method as in claim 5 including the further step,  
following Step e), of
- b) combining the traffic channel data symbols  
demodulated in Step e) for each transmission path identified in Step a),  
5 whereby the signal to noise ratio of a received message is improved.
9. A method as in claim 8 wherein the transmitted  
broadcast channel data and reference symbols are spread with a  
predetermined long code, unique to each base station, in which Step a)  
includes identifying the long code used to spread the broadcast channel  
5 message received on each transmission path, whereby a base station is  
identified, and in which Step b) includes generating the long code  
identified in Step a) to despread the broadcast channel reference and data  
symbols, and the traffic channel reference and data symbols.
10. A method as in claim 9 wherein each base station  
spreads the broadcast channel special timing symbol with only a  
predetermined first short code, wherein each mobile station has at least a  
first matched filter to despread the first short code, and in which the  
5 desreading of every received broadcast channel special timing symbol in  
Step a,) yields the identification of distinct transmission paths in Step a).
11. A method as in claim 10 wherein each mobile station  
includes a second matched filter, with the first matched filter operatively  
connected to a first antenna and the second matched filter operatively  
connected to a second antenna, and in which Step a) includes the  
5 identification of transmissions paths from the base station to each of the

mobile station antennas, whereby the diversity of the mobile station receiver is enhanced with the use of independent transmission paths.

12. A method as in claim 10 wherein the broadcast channel data and reference symbols are spread with a predetermined second short code, wherein the transmitted broadcast and traffic channel messages are modulated at a first chip rate, wherein the mobile station  
5 includes a broadcast channel RAKE receiver with a plurality of fingers, in which Step b) assigns a broadcast channel RAKE receiver finger to each transmission path identified in Step a) to generate short and long codes, and in response to generated short and long codes, generating a clock  
10 signal at the first chip rate, whereby the chip rate is generated for use with every channel of the assigned transmission path.

13. A method as in claim 12 wherein each base station assigns each mobile a third short code, unique to each mobile station, wherein the base station spreads the traffic channel message to a mobile station with its assigned third short code, wherein each mobile station  
5 includes a traffic channel RAKE receiver with a plurality of fingers, in which Step b) includes multiplying the broadcast channel data and reference symbols by the long code, to generate a long code despread signal, and including further sub-steps of Step b), of:

b.) for each transmission path identified in Step a),  
10 identifying the transmitted traffic channel messages spread with the mobile station's third short code;



- b<sub>2</sub>) for each transmission path identified in Step a),  
assigning a traffic channel RAKE receiver finger to the corresponding  
broadcast channel RAKE receiver finger assigned in Step b);
- 15           b<sub>3</sub>) in response to the first chip rate clock signal generated  
in Step b), generating the third short code; and
- b<sub>4</sub>) multiplying the long code despread signal generated in  
Step b) by the third short code generated in Sub-step b<sub>3</sub>), to completely  
despread the traffic channel message.

14. A method as in claim 13 wherein each mobile station  
includes a transmitter, in which Step a) includes receiving  
communications from at least two base stations, a first base station and a  
second base station, in which Step a) includes identifying at least one  
5 transmission path between each base station and the mobile station, and  
including the further steps, following Step b), of:
- i) in response to the despreading of the broadcast  
channel of the first base station, transmitting a request to the second base  
station to adjust the timing of the traffic channel transmission, whereby  
10 the timing differences between the first and second base stations are  
minimized;
- j) receiving the adjusted traffic channel transmission of  
the second base station; and
- k) in response to Step h), summing the combined traffic  
15 channel demodulated data symbols for the first and second base station,  
whereby diversity is increased with the use of two base stations.

15. A method as in claim 5 wherein broadcast and traffic control messages are organized into a series of time multiplexed slots, and in which Step d) includes broadcast and traffic channel RAKE receivers estimating weights and phase shifts to apply, to the demodulation of traffic channel data symbols in Step e), through an interpolation process using the weight and phase shift estimates from present, as well as succeeding slots.

16. A method as in claim 5 wherein broadcast and traffic control messages are organized into a series of time multiplexed slots, and the traffic channel data symbols include a transmit power control (TPC) bit, in which Step e) includes demodulating the TPC bit with the traffic channel data symbols, and in which Step d) includes broadcast and traffic channel RAKE receivers estimating weights and phase shifts, to apply to the demodulation of the TPC bit in Step e), through an extrapolation process using the weight and phase shift estimates from present, as well as previous slots.

17. In a code division multiple access (CDMA) communication system having a plurality of base stations asynchronously transmitting to a plurality of mobile stations, the communications from a base station to a mobile station being formatted in a plurality of coded channels including a broadcast channel message propagating along at least one transmission path, with a corresponding path delay, the broadcast channel message including predetermined time multiplexed reference and special timing symbols, a method for each mobile station to receive base station communications comprising the steps of:

- 10           a)    despreading at least one broadcast channel special  
timing symbol;
- b)    identifying a transmission path in response to each  
broadcast channel special timing symbol despread in Step a);
- c)    despreading the broadcast channel reference symbols  
15 for each transmission path identified in Step b); and
- d)    in response to the broadcast channel reference symbols  
despread in Step c), identifying at least one base station from which  
transmissions are being received, whereby the codes and timing for each  
communicating base station are derived by the mobile station.

18.    A method as in claim 17 wherein each base transmits  
at least one traffic channel message, unique to each mobile station, each  
traffic channel message including time multiplexed data symbols, and  
including the further step, following Step d), of:

- 5           e)    in response to broadcast channel timing determined in  
Step a) and the base station identification made in Step d), despreading  
the broadcast and traffic channel messages for each transmission path  
identified in Step b);
- f)    in response to the broadcast channel reference symbols  
10 despread in Step e), demodulating the broadcast channel reference  
symbols;
- g)    in response to Step f), interpolating weights and phase  
shifts, to demodulate the traffic channel data symbols; and
- h)    for each base station identified in Step d), combining  
15 the traffic channel data symbols demodulated from each transmission  
path identified in Step b), with the weights and phase shifts interpolated

in Step g), whereby the signal to noise ratio of a base station transmission is improved.

19. A method as in claim 18 wherein the traffic channel message includes predetermined time multiplexed reference symbols, in which Step e) includes despread the traffic channel reference symbols, in which Step f) includes demodulating the traffic channel reference  
5 symbols, and in which Step g) includes interpolating weights and phase shifts in response to the demodulated traffic channel reference symbols.

20. In a code division multiple access (CDMA) communication network having a plurality of base stations asynchronously transmitting information to a plurality of mobile stations, the coded communications from a base station to a mobile station being  
5 formatted in a plurality of channels including a broadcast channel message and at least one traffic channel message, with each broadcast and traffic channel message propagated along at least one transmission path, with a corresponding path delay, the broadcast channel message including predetermined time multiplexed reference symbols and a special  
10 timing symbol, and the traffic channels message including time multiplexed data symbols, a mobile station receiver to accept base station communications comprising:

at least a first filter matched to despread the broadcast channel special timing symbol, said first matched filter having an input to  
15 accept the broadcast channel special timing symbol received for each transmission path from a communicating base station, and a first output to provide the despread special timing symbol for each transmission path,

whereby multiplex timing information for the broadcast channel is provided;

20 a timing and code management circuit having a first input operatively connected to said first matched filter output to accept despread special timing symbols for each transmission path, said timing and code management circuit having a first output to provide the despread special timing symbol for each transmission path, and a second  
25 output to provide channel multiplex timing information and base station identification for each transmission path;

a traffic channel RAKE receiver having a plurality of fingers, each finger having an input operatively connected to said timing and code management circuit second output, each said finger using the broadcast  
30 channel multiplex timing and base station identification information provided by said timing and code management circuit to despread the traffic channel data symbols for each transmission path, whereby the timing and coding needed to despread the traffic channel results from despreading the broadcast channel.

21. A receiver as in claim 20 wherein each base station is assigned a unique long code, and the base stations transmit broadcast channel reference symbols spread with their long code, and further comprising:

5 a searcher unit having a first input to accept the broadcast channel reference symbols for each transmission path, a second input operatively connected to said timing and code management circuit first output to accept the despread broadcast channel special timing symbol for each transmission path, said searcher unit identifying the long code for

10 the broadcast channel received on each transmission path, said searcher  
unit having an output to provide the long code of the broadcast channel  
for each transmission path, whereby the base station is identified; and  
in which said timing and code management circuit includes a  
second input operatively connected to said searcher unit output to accept  
15 the identified broadcast channel long code for each transmission path, and  
in which said second output provides broadcast channel long codes, as  
well as channel timing information, for each transmission path.

22. A receiver as in claim 21 wherein each base station  
transmits broadcast and traffic channels messages modulated at a  
predetermined first chip rate, wherein the transmitted broadcast channel  
special timing symbols are spread with just a predetermined first short  
5 code, wherein the broadcast channel reference symbols are spread with  
the long code and a predetermined second short code, and wherein the  
traffic channel data symbols are spread with the long code, the mobile  
station receiver further including a broadcast channel RAKE receiver with  
a plurality of fingers, with each finger assigned to a transmission path,  
10 and in which each finger of said broadcast channel RAKE receiver  
comprises:

a delay locked loop (DLL) having a first input operatively  
connected to the output of said timing and code management circuit, a  
second input to accept broadcast and traffic channel messages, and a first  
15 output to provide the first chip rate clock signal.

23. A receiver as in claim 22 wherein each base station  
modulates the transmitted data and reference symbols, wherein broadcast

channel messages include data symbols spread by the long code and the second short code, in which said DLL has a second output to provide the  
5 despread broadcast channel data and reference symbols, and each said broadcast channel RAKE receiver finger further comprising:

a broadcast channel estimation and weighting circuit having an input operatively connected to said DLL second output to receive the despread broadcast channel reference and data symbols, said broadcast  
10 channel estimation and weighting circuit demodulating the broadcast channel reference symbols to determine the assigned transmission path weights and phase shifts, and to estimate weights and phase shifts to apply during the demodulation of broadcast and traffic channel data symbols, said broadcast channel finger estimation and weighting circuit  
15 having a first output to provide the demodulated broadcast channel data symbols, and a second output to provide weight and phase shift estimations for use with the traffic channel of the assigned transmission path.

24. A receiver as in claim 23 further comprising:

a first summing circuit having a plurality of inputs operatively connected to said broadcast channel estimation and weighting circuit first output of each said broadcast channel RAKE receiver finger,  
5 said first summing circuit combining the demodulated broadcast channel data symbols to provide an output with demodulated broadcast channel data symbols having an improved signal to noise ratio, whereby multipath broadcast channel messages are combined.

25. A receiver as in claim 24 wherein the base station assigns a third short code to each mobile station, which is unique for each mobile station, and transmitted traffic channel data symbols are spread with the third short code, in which said broadcast channel DLL has a  
5 third output to provide the long code despread signal which is a product of the long code multiplied by broadcast and traffic channel messages, and in which each finger of said traffic channel RAKE receiver corresponds to a finger of said broadcast channel receiver having the same assigned transmission path, each said traffic channel RAKE receiver finger  
10 comprising:

a traffic channel code generator to generate the third short code, said traffic channel code generator having an input operatively connected to said DLL first output to accept the first chip rate clock signal, and an output to provide the mobile station's assigned third short  
15 code at a rate matching the traffic channel message received on that transmission path; and

a traffic channel mixer having a first input operatively connected to said traffic channel short code generator output, a second input operatively connected to said DLL third output in said  
20 corresponding broadcast channel finger, to accept the long code despread signal, and an output to provide the despread traffic channel data symbols.

26. A receiver as in claim 25 in which each said traffic channel finger further comprises:

a traffic channel estimation and weighting circuit having a first input operatively connected to the output of said traffic channel



3 mixer to accept the despread traffic channel data symbols, a second input  
operatively connected to said broadcast channel estimation and weighting  
circuit second output in said corresponding broadcast channel finger, said  
traffic channel estimation and weighting circuit accepting the estimated  
weights and phase shifts from the broadcast channel estimation and  
10 weighting circuit to aid in the demodulation of the traffic channel data  
symbols, said traffic channel finger estimation and weighting circuit  
having a first output to provide the demodulated traffic channel data  
symbols.

27. A receiver as in claim 26 in which said traffic channel  
estimation and weighting circuit demodulates the traffic channel  
reference symbols to determine the assigned transmission path weights  
and phase shifts, and estimates the weights and phase shifts for  
5 application in the demodulation of traffic channel data symbols.

28. A receiver as in claim 27 further comprising:  
a second summing circuit having a plurality of inputs  
operatively connected to said traffic channel estimation and weighting  
circuit output of each said traffic channel RAKE receiver finger for a  
5 transmitting base station, said second summing circuit having an output  
to provide the sum of the demodulated traffic channel data symbols for  
each transmission path from a base station, whereby the signal to noise  
ratio of the received information is improved by combining signals of each  
transmission path.

29. A receiver as in claim 28 wherein the base station transmissions are radiated through space, and further comprising:

a first antenna having an input to accept the radiated transmissions of the base stations and an output to provide broadcast and traffic channel messages;

a second antenna having an input to accept the radiated transmissions of the base stations and an output to provide broadcast and traffic channel messages;

a second filter matched to despread the broadcast channel special timing symbol, said second matched filter having an input operatively connected to said second antenna output to accept the broadcast channel special timing symbols received for each transmission path from a base station to said second antenna, and a first output to provide the despread special timing symbols for each transmission path, whereby a timing pulse is provided;

in which said first matched filter input is operatively connected to said first antenna output to accept the broadcast channel special timing symbols received for each transmission path from a base station to said first antenna;

in which said timing and code management circuit includes a third input operatively connected to said second matched filter output;

and

in which each said broadcast channel RAKE receiver finger includes a switch having a first input operatively connected to said first antenna output, a second input operatively connected to said second antenna output, and an output operatively connected to said DLL second input to selectively supply the broadcast and traffic channel messages

from alternate antennas, whereby the diversity of two antennas is used to increase the signal to noise ratio of the demodulated messages.

30. A receiver as in claim 28 wherein traffic channel RAKE receiver fingers are grouped by transmitting base station, wherein the receiver receives communications from at least two base stations, and further comprises:

5 a logic unit operatively connected to the receiver to receive broadcast channel multiplex timing information from each said broadcast channel RAKE finger, and to compare the broadcast channel timing information from the at least two base stations, said logic unit having an output to provide a message requesting a timing adjustment to the traffic  
10 channel of at least one base station;

a transmitter having an input operatively connected to the logic unit output to receive traffic channel timing requests, said transmitter having an output to transmit timing adjustment messages to communicating base stations;

15 in which said second summing circuit is a plurality of summing circuits, with each said second summing circuit summing the multipathed traffic channel data symbols of a different transmitting base station; and

a third summing circuit having a plurality of inputs  
20 operatively connected to said second summing circuit outputs, and an output to provide the sum of the traffic channel data symbols of different transmitting base stations, whereby the traffic channel symbols from multiple base stations are summed for an enhanced signal to noise ratio message.

31. A receiver as in claim 30 wherein broadcast and traffic control messages are organized into a series of time multiplexed slots, and in which said broadcast and traffic channel RAKE receivers estimate weights and phase shifts to apply to the demodulation of traffic channel data symbols through an interpolation process using the weight and phase shift estimates from present, as well as succeeding slots.

32. A receiver as in claim 30 wherein broadcast and traffic control messages are organized into a series of time multiplexed slots, and the traffic channel data symbols include a transmit power control (TPC) bit, and in which said broadcast and traffic channel RAKE receivers estimate weights and phase shifts to apply to the demodulation of the TPC bit through an extrapolation process using the weight and phase shift estimates from present, as well as previous slots.

33. In a code division multiple access (CDMA) communication system having a plurality of base stations asynchronously communicating to a plurality of mobile stations, the communications from a base station to a mobile station being formatted in a plurality of coded channels including a broadcast channel message and a traffic channel message propagating along at least one transmission path, with a corresponding path delay, the broadcast channel message including predetermined time multiplexed reference and special timing symbols, and the traffic channel message including time multiplexed data symbols, a method for each mobile station to synchronize communications from at least two base stations comprising the steps of:

- a) despread at least one broadcast channel special timing symbol from each base station;
- b) establishing the broadcast channel multiplex timing for a transmission path, in response to each broadcast channel special timing symbol despread in Step a);
- 15 c) despread the broadcast channel reference symbols for each transmission path identified in Step b);
- d) in response to the broadcast channel reference symbols despread in Step c), identifying at least two base stations from which transmissions are being received;
- 20 e) demodulating the broadcast channel reference symbols for each transmission path identified in Step b);
- f) in response to the broadcast channel reference symbols demodulated in Step e), refining the broadcast channel multiplex timing established in Step b);
- 25 g) comparing the broadcast channel timing, refined in Step e) from at least two base stations; and
- h) in response to the comparison made in Step g), transmitting a request to one of the at least two base stations to adjust its transmission of the traffic channel, whereby the delay between the transmissions of traffic channels by different base stations is minimized.

34. A method as in claim 33 comprising the further steps, following Step c), of:

- i) completely despread the broadcast and traffic channel messages for each transmission path identified in Step b);
- 5 j) demodulating the traffic channel data symbols;

- k) for each base station identified in Step d), combining the traffic channel data symbols demodulated in Step j); and
- l) summing the traffic channel data symbols combined in Step k) for all the base stations identified in Step d), whereby the signal to noise ratio of the received message is enhanced from the diversity of combining each transmission path, as well as each base station.
- 10

FIG.1

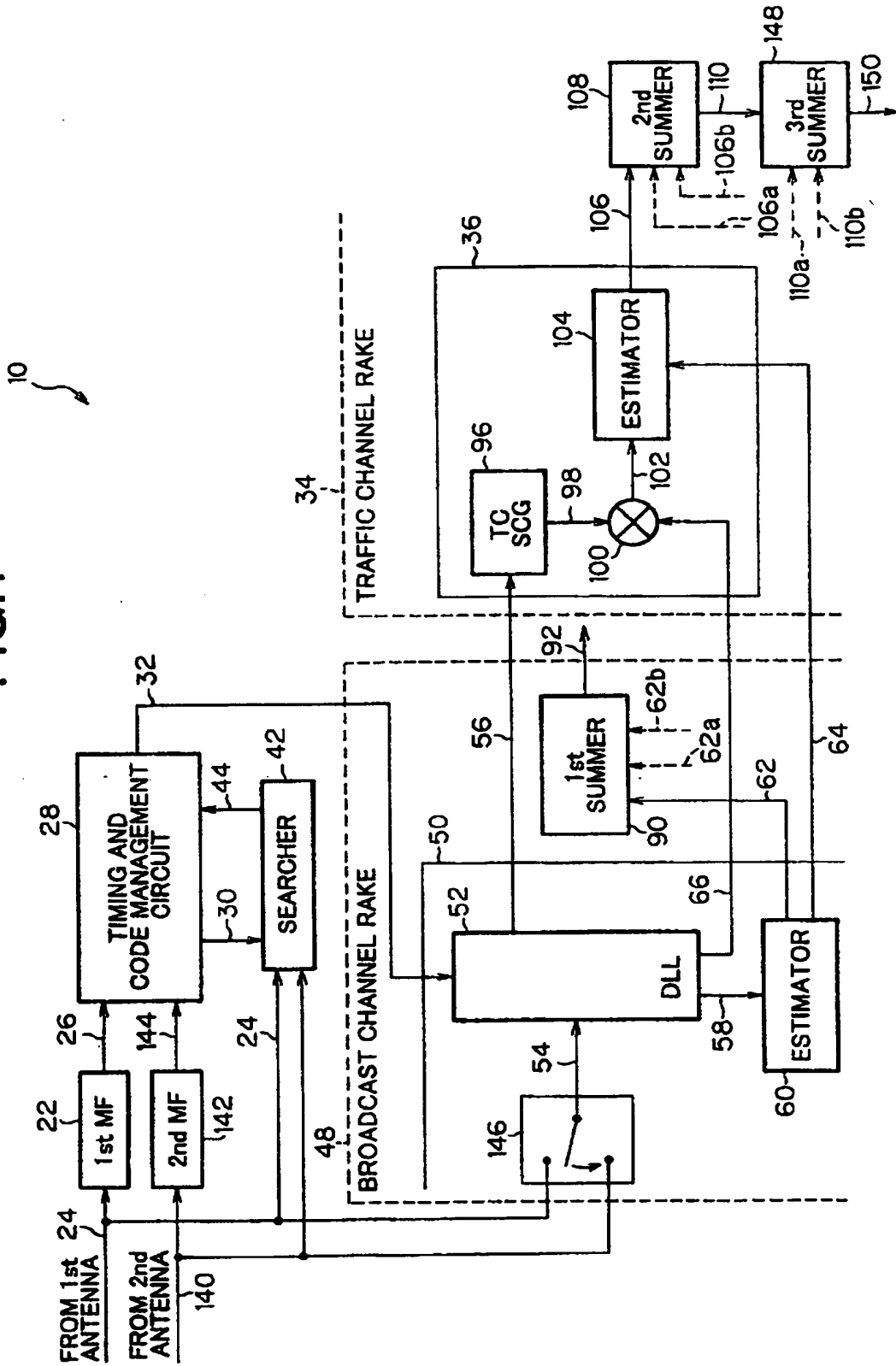

1/e

# FIG.2

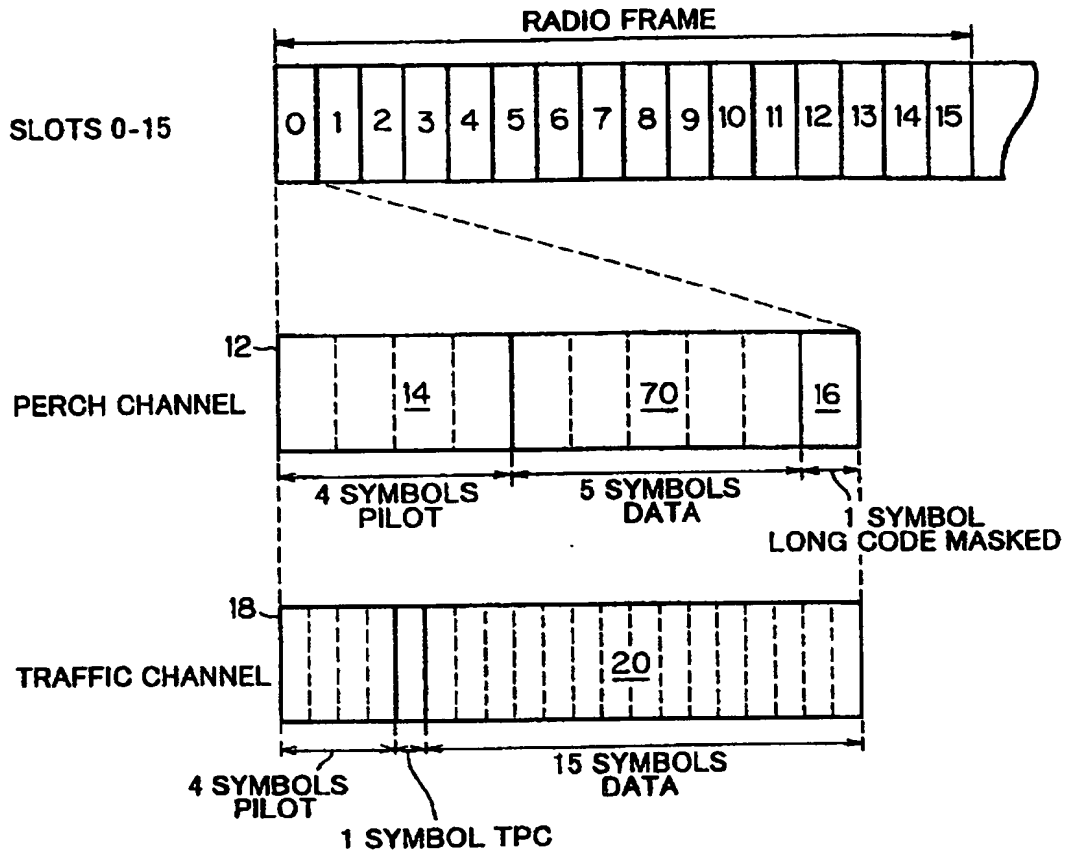



FIG.3

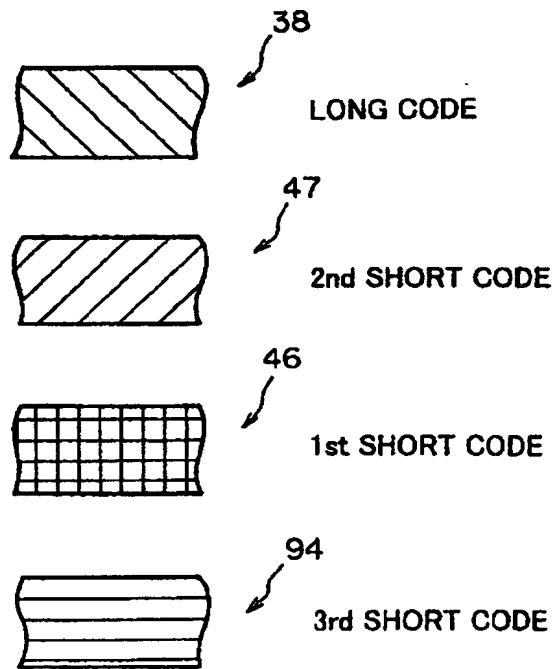
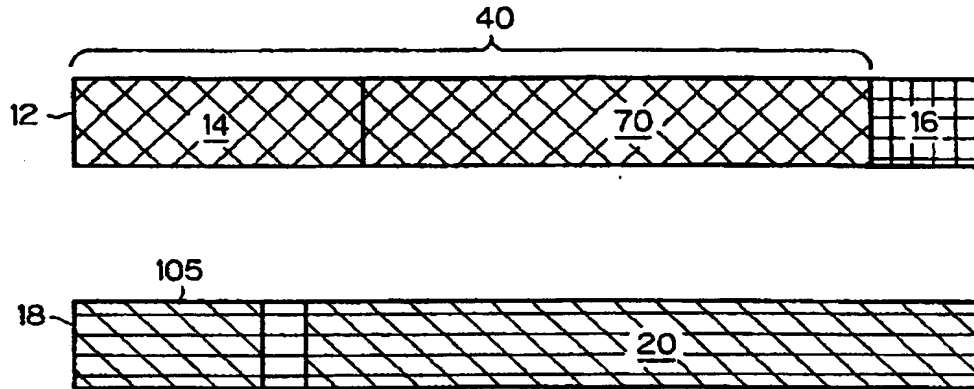

FIG.4

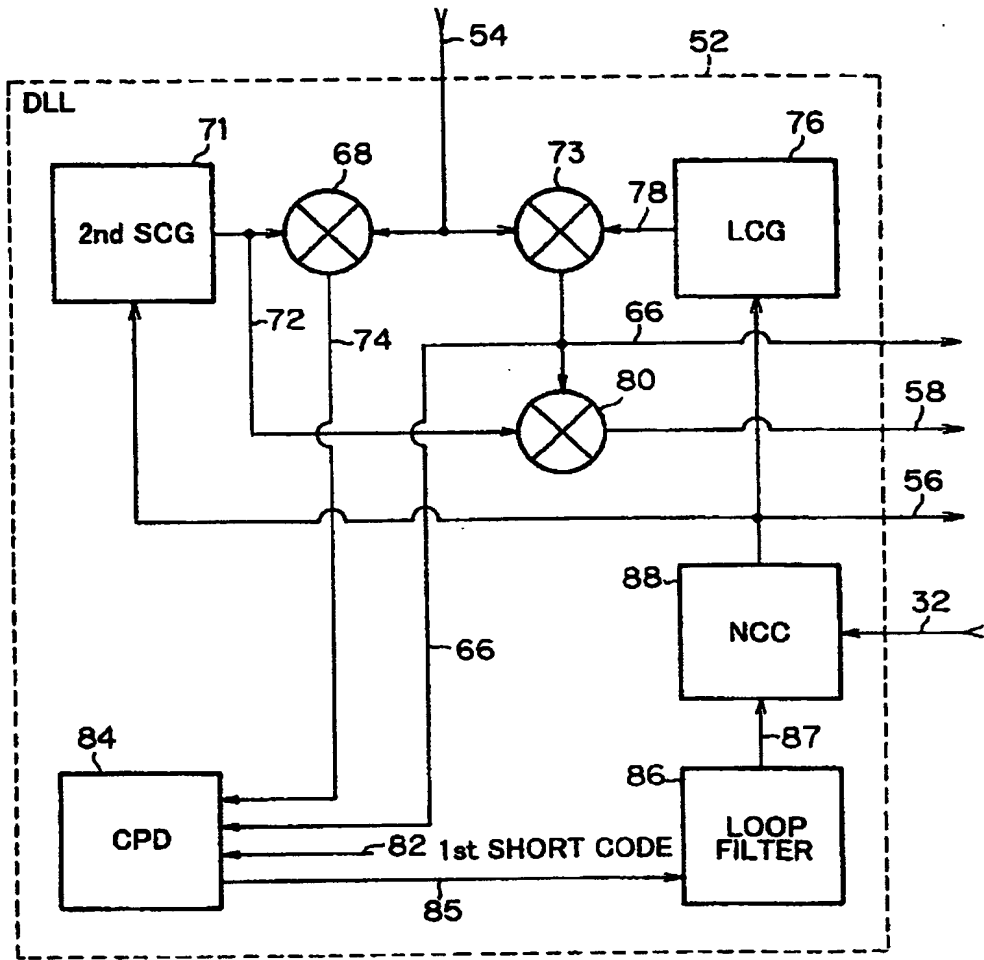

FIG.5

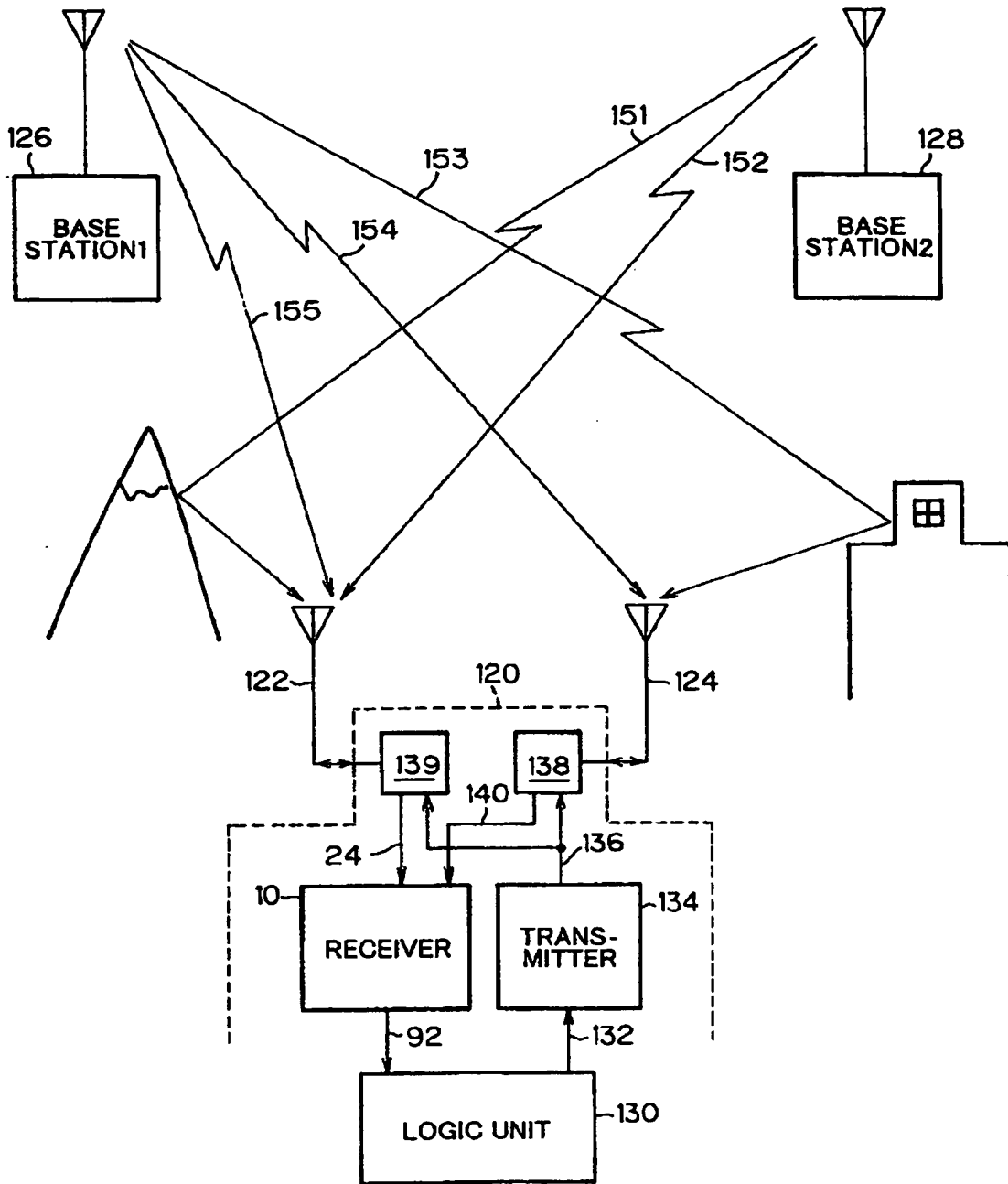

FIG.6

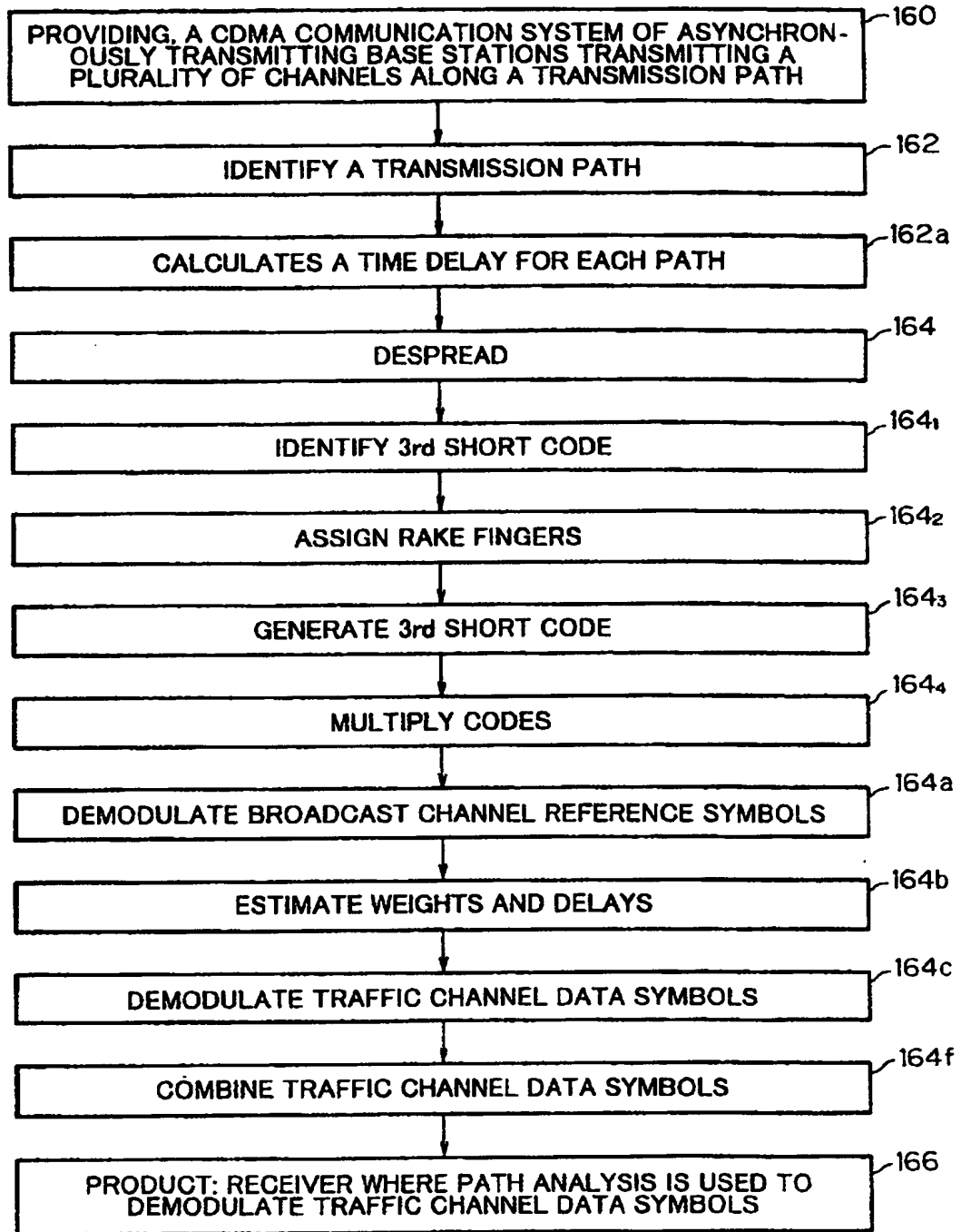

FIG.7

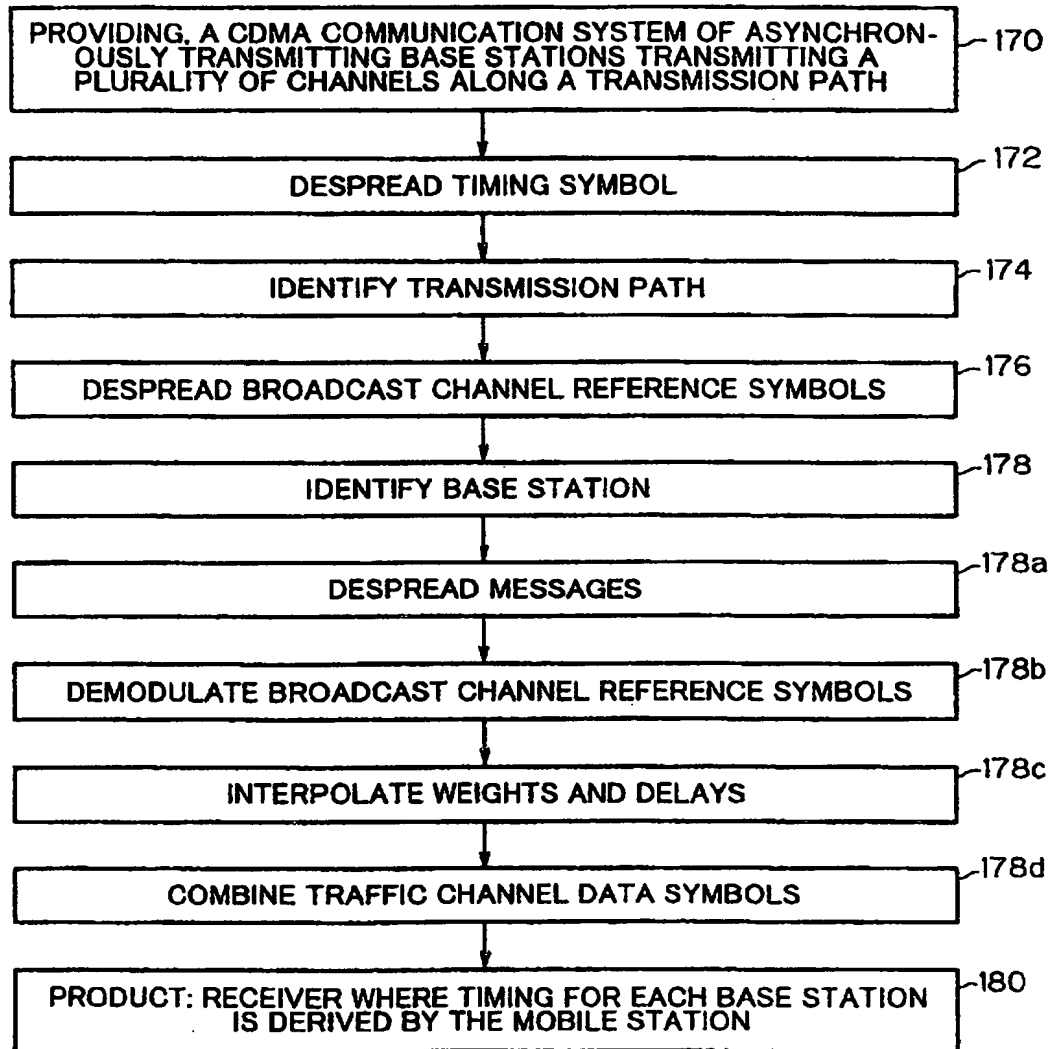
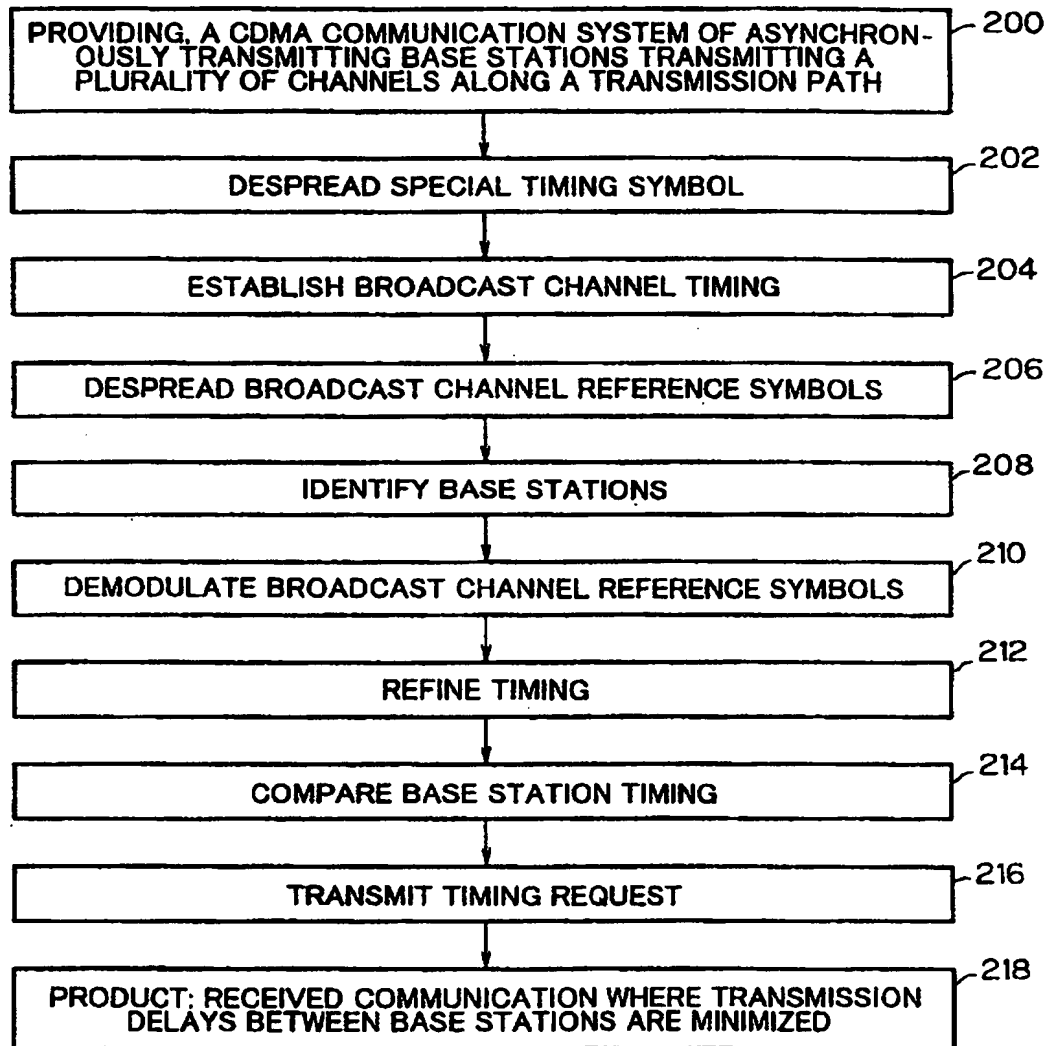

FIG.8



# INTERNATIONAL SEARCH REPORT

Int. :ional Application No  
**PCT/JP 99/00327**

**A. CLASSIFICATION OF SUBJECT MATTER**  
**IPC 6 H04B1/707 H04B7/08 H04B7/26 H04J3/06**

According to International Patent Classification (IPC) or to both national classification and IPC

**B. FIELDS SEARCHED**

Minimum documentation searched (classification system followed by classification symbols)  
**IPC 6 H04B H04J**

Documentation searched other than minimum documentation to the extent that such documents are included in the fields searched

Electronic data base consulted during the international search (name of data base and, where practical, search terms used)

**C. DOCUMENTS CONSIDERED TO BE RELEVANT**

Category *	Citation of document, with indication, where appropriate, of the relevant passages	Relevant to claim No
Y  A	<p><b>WO 97 33400 A (OHNO KOJI ;ADACHI FUMIYUKI (JP); HIGASHI AKIHIRO (JP); HIGUCHI KEN) 12 September 1997</b></p> <p>-&amp; <b>EP 0 825 737 A (NTT MOBILE COMMUNICATIONS NETWORK INC.) 25 February 1998</b>                      see abstract                      see column 4, line 52 - column 5, line 31                      see column 6, line 1 - line 16                      see column 8, line 48 - column 9, line 38                      see column 12, line 55 - column 13, line 11                      see column 14, line 26 - column 15, line 6                      see column 16, line 26 - column 17, line 4                      see column 18, line 24 - line 33                      see column 22, line 16 - line 45</p> <p style="text-align: center;">-/--</p>	<p>1-4, 17, 33, 34</p> <p>7-10, 12, 13, 18, 20-22, 34</p>

Further documents are listed in the continuation of box C.       Patent family members are listed in annex.

\* Special categories of cited documents :

<p>"A" document defining the general state of the art which is not considered to be of particular relevance</p> <p>"E" earlier document but published on or after the international filing date</p> <p>"L" document which may throw doubts on priority claim(s) or which is cited to establish the publication date of another citation or other special reason (as specified)</p> <p>"O" document referring to an oral disclosure, use, exhibition or other means</p> <p>"P" document published prior to the international filing date but later than the priority date claimed</p>	<p>"T" later document published after the international filing date or priority date and not in conflict with the application but cited to understand the principle or theory underlying the invention</p> <p>"X" document of particular relevance; the claimed invention cannot be considered novel or cannot be considered to involve an inventive step when the document is taken alone</p> <p>"Y" document of particular relevance; the claimed invention cannot be considered to involve an inventive step when the document is combined with one or more other such documents, such combination being obvious to a person skilled in the art.</p> <p>"Z" document member of the same patent family</p>
--	--

Date of the actual completion of the international search <b>21 May 1999</b>	Date of mailing of the international search report <b>02/06/1999</b>
---	---

Name and mailing address of the ISA European Patent Office, P.B. 5816 Patentlaan 2 NL - 2280 HV Rijswijk Tel. (+31-70) 340-2040, Tx. 31 651 epo nl, Fax: (+31-70) 340-3016	Authorized officer  <b>Lustrini, D</b>
--	--

INTERNATIONAL SEARCH REPORT

International Application No  
PCT/JP 99/00327

C.(Continuation) DOCUMENTS CONSIDERED TO BE RELEVANT		
Category	Citation of document, with indication, where appropriate, of the relevant passages	Relevant to claim No.
Y A	<p>see column 23, line 34 - line 44 -----</p> <p>EP 0 795 971 A (MATSUSHITA ELECTRIC IND CO LTD) 17 September 1997 see abstract</p>	<p>1-4, 17  9, 10, 12, 13, 20-22, 34</p>
Y A A	<p>see column 5, line 7 - line 33 see column 7, line 45 - column 8, line 3 see column 9, line 17 - line 37 see column 11, line 18 - line 24 -----</p> <p>WO 94 30024 A (ERICSSON TELEFON AB L M) 22 December 1994 see abstract see page 7, line 29 - page 8, line 7 -----</p> <p>US 5 619 524 A (LING FUYUN ET AL) 8 April 1997 see abstract see column 4, line 31 - line 36 see column 4, line 55 - line 67 see column 13, line 4 - line 11 -----</p>	<p>33, 34  14  5, 6, 18, 19</p>
A	<p>EP 0 696 856 A (NIPPON ELECTRIC CO) 14 February 1996 see abstract see figure 5 -----</p>	<p>11</p>



**INTERNATIONAL SEARCH REPORT**

Information on patent family members

International Application No

PCT/JP 99/00327

Patent document cited in search report		Publication date	Patent family member(s)	Publication date
WO 9733400	A	12-09-1997	CA 2217575 A	12-09-1997
			EP 0825737 A	25-02-1998
EP 0795971	A	17-09-1997	JP 9307951 A	28-11-1997
			CN 1164785 A	12-11-1997
WO 9430024	A	22-12-1994	AU 677079 B	10-04-1997
			AU 7012994 A	03-01-1995
			CA 2141445 A	22-12-1994
			CN 1112385 A	22-11-1995
			EP 0659326 A	28-06-1995
			FI 950626 A	14-02-1995
			JP 8500474 T	16-01-1996
			NZ 267747 A	27-07-1997
			US 5828659 A	27-10-1998
			US 5619524	A
BR 9506385 A	16-09-1997			
CA 2176945 A	11-04-1996			
CN 1136378 A	20-11-1996			
EP 0732022 A	18-09-1996			
FI 962326 A	04-06-1996			
IL 114836 A	27-12-1998			
JP 9507014 T	08-07-1997			
PL 314846 A	30-09-1996			
WO 9610879 A	11-04-1996			
EP 0696856	A	14-02-1996		
			JP 8056213 A	27-02-1996
			AU 698943 B	12-11-1998
			AU 2859795 A	22-02-1996
			CA 2155817 A	12-02-1996
			US 5687162 A	11-11-1997